

Performance Study of Power Control Method for Chopper Fed Separately Excited DC (Direct Current)-Drive using PSIM

Anant Kumar Verma

*Electrical Department, Dehradun Institute of Technology, Dehradun,
Uttarakhand, INDIA*

Gagan Singh

*Electrical Department, Dehradun,
Uttarakhand, INDIA
E-mail: gaganus@gmail.com
www.dit.edu.in*

Abstract

This paper presents conventional Power control method for Separately Excited DC motor using specifically designed simulation software package PSIM for Power Electronics and motor control. Armature voltage control is preferred because of high efficiency and good speed regulation for dc motors. The speed control of separately excited dc drive can be done using four quadrant chopper up to rated speed. Choppers are widely used for traction motor control in transportation systems. Power control interprets as FORWARD/REVERSE MOTORING of DC drive.

Keywords: DC drive, Choppers, PSIM, Simulation, Power (acceleration) control.

1. Introduction

In traction applications Dc-Dc converters (or choppers) are used all over the world. A wide range of control methods are present and hence Dc-Dc converters provide very effective armature control. For having a proper control over a DC motor, it's a necessary condition to have a rectified AC supply or DC supply at motor's armature terminals. In present scenario DC motors are best suited for their good speed regulation for accelerating or decelerating motions. Complexity of AC drives as compared to DC drives is much higher, hence affecting the cost of maintenance and controlling of the AC drive. Dc motors are capable of providing very high starting and accelerating torques in excess of 400% of the rated [1]. In order to understand the work

proposed in [1], we have focused on the controlling methods for DC drive with the help of DC-Choppers. The various control methods applicable to DC drives (only for DC-DC converter drives) are as follows:

- Power control (or acceleration) Control (PC).
- Regenerative Brake Control.
- Rheostatic Brake control.
- Combined Regenerative and Rheostatic Brake Control (CRRBC).

1.1. DC Chopper

It is a power electronic device, static in nature. The most basic work of the chopper arrangement circuit is to change constant Dc voltage to an adjustable Dc voltage

without any intermediate energy storage element (inductor/ capacitor). A quasi-rectangular version of the input DC voltage is obtained as a output of a chopper after input voltage is chopped off for a certain duration. Types of DC-choppers available according to their output V_o (output voltage)- I_o (output current) capabilities are as follows :

- First quadrant I + V_o + I_o
- Second quadrant II + V_o - I_o
- Two quadrant I and II + V_o + I_o , - I_o
- Two quadrant I and IV + V_o , - V_o + I_o
- Four quadrant I,II,III, and IV + V_o , - V_o + I_o , - I_o

The basic Four quadrant chopper type is selected for the purpose to be severd for controlling a DC drive also known as the “H-BRIDGE CHOPPER”[4]. The major circuit consists of four MOSFETs which forms a H – bridge, hence provides variable DC voltage for our Load known to us as Separately excited DC motor. The power semiconductor device MOSFET is so chosen because of its high switching speeds and 0.5 to 2.5 volt drop across them. Also, many other available devices can serve the purpose.

2. Literature review

Due to the recent advancement in the power electronics and power conversion methods including the digital computers the AC motor drives are enhancing into a competitive world in respect to the DC motor drives. DC-DC converters are boon to the power electronics controlled systems. Since their ability to provide continuously variable DC voltage, DC-DC converters are used for control equipment in modern industrial drives and variable-speed drives. DC drives can be distinguished into three general types:

- Single-phase drives.
- Three- phase drives.
- DC-DC-Converter Drives.

2.1.1 General characteristics of a Dc motor

When separately excited DC motor is excited by a field current of “ I_f ” and an armature current of “ I_a ” flows in the armature circuit, The motor develops a back electromotive force(emf) and a torque to balance the

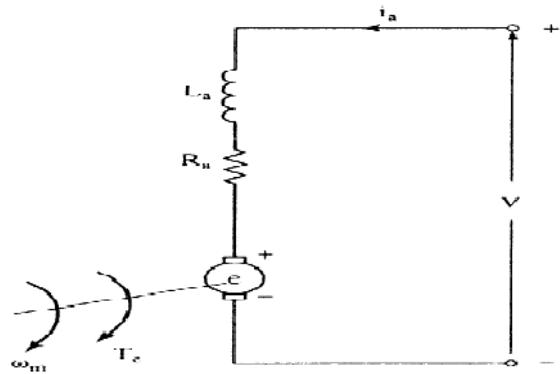

Fig. 1. Equivalent circuit of Dc armature [2].

load torque at a particular speed. The field current “ I_f ” of a separately excited DC motor is independent of the

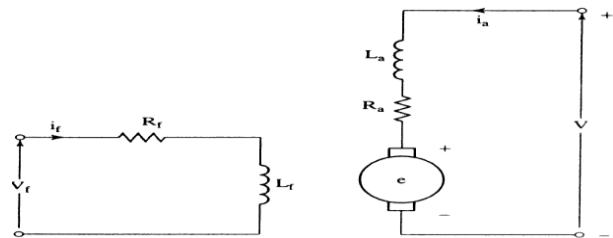

Fig. 2. separately excited dc motor with field winding [2].

armature current “ I_a ” and any change in the armature current has no effect on the field current. The field current is normally much less than the armature current.[3]

The equation of a separately excited DC motor can be determined using fig.3.

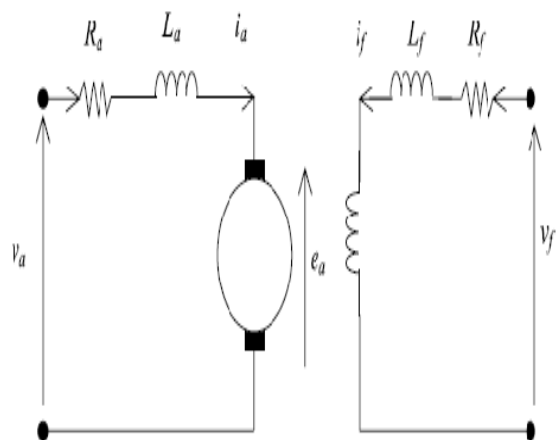

Fig. 3. separately excited dc motor [3].

The armature equivalent circuit consists of a armature resistance R_a , self inductance L_a , and an induced emf. The input in case of motors is Electrical energy and output is Mechanical energy.

2.1.2 Operating principle of a chopper

As the name suggests, the chopper is a semiconductor device (switch) which provides a keen relationship between input and output parameters at fast switching rate therefore at times when the switch is on the input will be connected to the load ,when switch is off the load is disconnected from the input. Now to understand the concept in a better way we will analyze the input/output relationship through waveforms provided below in Fig. 4. to a single semiconductor switch, hence forth we can judge what are the parameters which are controllable for our purpose, So as to produce variable DC output.

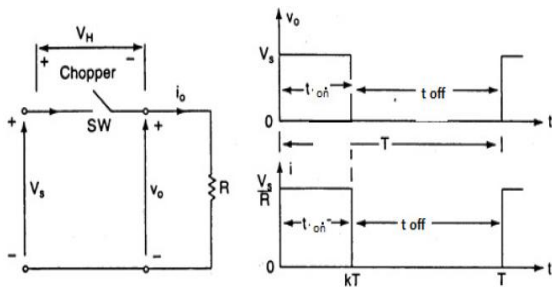

Fig. 4. Circuit and waveform [1],[6],[3].

Average Voltage,

$$V_o/V_s = (T_{on}/(T_{on}+T_{off})) \tag{1}$$

$$V_o = (T_{on}/T)*V_s \tag{2}$$

$$V_o = \alpha * V_s \tag{3}$$

$$\alpha = T_{on}/T \tag{4}$$

Uncontrolled parameters:

- V_s = source voltage.

Controlled parameters:

- α = Duty ratio.
- $T = T_{on} + T_{off}$ =Chopping period.
- T_{on} =ON period.
- T_{off} =OFF period.
- $f = 1/T$ = Chopping Frequency.

From above discussion we reach to a conclusion that the power flow can be controlled by using controlled parameters. The power control can be done by two operations:

- Constant Frequency Operation: In this operation, switching frequency is kept constant and T_{on} is varied. Effect of this method changes the width of the controlling pulse and therefore called Pulse Width Modulation (PWM) control.
- Variable Frequency Operation: In this operation, switching frequency is varied and T_{on} or T_{off} is kept constant. Also known as Frequency Modulation.

3. Buck and Boost Converters

At this stage, it is necessary to learn about the conventional converters used in the power electronic systems (PES). A clear concept about these converters leads a path towards designing a four quadrant chopper. Step down (buck) switching converters are the integral part of the modern electronics. Step down converters transfer small packets of energy using a switch, a diode, an inductor and several capacitors. (refer fig.5.)

Step up (boost) switching converters transfers large

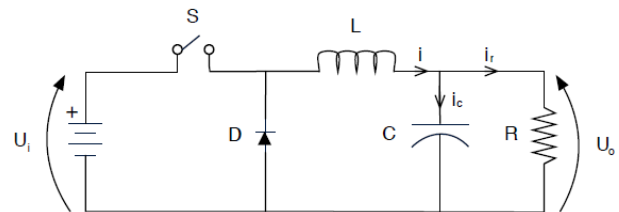

Fig. 5. Buck converter [5].

packets of energy using similar devices as mentioned for buck converters but with slight changes in the circuit arrangements.(refer fig.6.)

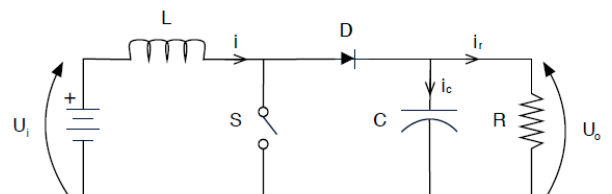

Fig. 6. Boost converter [5].

Average output voltage of Buck converter in terms of duty ratio.

$$V_o = \alpha V_s \tag{5}$$

Average output voltage of Boost converter in terms of duty ratio.

$$V_o = V_s / (1 - \alpha) \tag{6}$$

The capacitor and an inductor present in the buck (or boost) system provides us a knowledge, to learn our designed systems characteristics under dynamic conditions such as fast switching rate of the Switch and other disturbances present due to load changes or environmental effects. Hence, State Space tool for modeling systems is very much suited for dynamical behavior of a system.

4. Mathematical modeling of Buck and Boost Converters in State Space for the Dynamic behavior

Assuming that parameter shown in Fig .5 and Fig .6 Are analogous to our present conventional relationship for input and output variables. Here

$$U_i = \text{input variable}$$

$$U_o = \text{output variable}$$

Applying Kirchoff's voltage law assuming switching (S=1) on both the converters separately we arrive to mathematical model in state space [5] ,[12].

$$di/dt = (Su_i - u_c)/L \tag{7}$$

$$du_o/dt = i/C - u_o/RC \tag{8}$$

For(S=1):

$$\begin{bmatrix} \dot{i} \\ \dot{u}_o \end{bmatrix} = \begin{bmatrix} 0 & -\frac{1}{L} \\ \frac{1}{C} & -\frac{1}{RC} \end{bmatrix} \begin{bmatrix} i \\ u_o \end{bmatrix} + \begin{bmatrix} \frac{u_i}{L} \\ 0 \end{bmatrix} \tag{9}$$

For (S=0):

$$\begin{bmatrix} \dot{i} \\ \dot{u}_o \end{bmatrix} = \begin{bmatrix} 0 & -\frac{1}{L} \\ \frac{1}{C} & -\frac{1}{RC} \end{bmatrix} \begin{bmatrix} i \\ u_o \end{bmatrix} \tag{10}$$

Final state model after combining equation no. 9 and 10 is as follows:

$$\begin{bmatrix} \dot{i} \\ \dot{u}_o \end{bmatrix} = \begin{bmatrix} 0 & -\frac{1}{L} \\ \frac{1}{C} & -\frac{1}{RC} \end{bmatrix} \begin{bmatrix} i \\ u_o \end{bmatrix} + \begin{bmatrix} \frac{u_i}{L} \\ 0 \end{bmatrix} S \tag{11}$$

Similarly,

For boost converter final state model will be:

$$\begin{bmatrix} \dot{i} \\ \dot{u}_o \end{bmatrix} = \begin{bmatrix} 0 & -\frac{(1-S)}{L} \\ \frac{(1-S)}{C} & -\frac{1}{RC} \end{bmatrix} \begin{bmatrix} i \\ u_o \end{bmatrix} + \begin{bmatrix} \frac{u_i}{L} \\ 0 \end{bmatrix} \tag{12}$$

5. Four Quadrant Chopper (4Q) Operation

As we have thoroughly understood the concepts of choppers, their types and dynamic modeling. It will be easier for us now to predict the H-bridge chopper results visually going through the circuit diagram. The four quadrant operation of choppers is wholly dependent on the buck and boost converter operations.

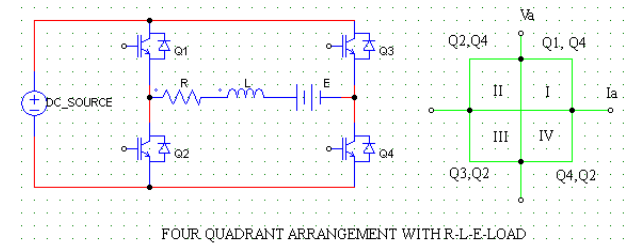

Fig. 7. Four quadrant (4Q) circuit diagram.

1st quadrant mode:

- Switch Q4 is kept on and Q1 is modulating.

	Q1-ON	Q1-OFF
Current direction	V-Q1-R-L-E-Q4	R-L-E-S4-D2

- Va and Ia are +ve.
- Step Down Chopper.

2nd quadrant mode:

- Switch Q2 is modulating and Q1,Q3,Q4 are kept off.
- Inductor L stores energy during the time Q2 is on.

Current direction	E-L-R-Q2-D4
-------------------	-------------

- Va is +ve and Ia is -ve.
- Step Up Chopper.

3rd quadrant mode:

- Switch Q3 is modulating, Q1 is kept off , and Q2 is kept on.

- Polarity of E must be reversed , when Q3 is load gets connected to source voltage hence both Va and Ia becomes -ve .
- Current freewheels through Q2 and D4 as Q3 is off.
- Step Down Chopper.

4th quadrant mode:

- Switch Q4 is modulating and other switches are kept off.
- Inductor L stores energy during the time Q4 is on.

	Q4 -ON	Q4-OFF
Current direction	Q4-D2-L-E	D2-D3

- Va is -ve and Ia is +ve.
- Step Up Chopper.

6. Principle of Power (or acceleration) Control

The choppers discussed earlier are used to control armature voltage of a Dc motor. The dc-dc converter switch could be any semiconductor switching device such as transistors or forced commutated thyristor. In industrial environment essential loads will be R-L-E. The theoretical concepts were always developed from ideal conditions, assuming a highly inductive load.

The average armature voltage [3]:

$$V_a = KV_s \tag{13}$$

Where k is the duty cycle of the dc-dc- converter, The power supplied to the motor is

$$P_o = KV_s I_a = V_a I_a \tag{14}$$

Where “ I_a ” is the average armature current of the motor and it is ripple free. Assuming a lossless dc-dc converter, the input power is

$$P_i = P_o = KV_s I_s \tag{15}$$

The average value of the input current:

$$I_s = KI_a \tag{16}$$

The equivalent input resistance of the dc-dc converter drive seen by the source:

$$R_{sq} = \frac{V_s}{I_s} = \frac{V_s}{KI_a} \tag{17}$$

By varying the Duty –cycle K, the power flow to the motor (and speed) can be controlled.

7. Mathematical Model of Separately Excited DC Motor [3]

In contrast for every minute detail explained above a review of mathematics applied to Dc motors will be an additional advantage in modeling accuracy of Dc motors and will be helpful to understand the insight working of DC machines.

From fig.3:

The instantaneous field current I_f

$$v_f = R_f i_f + L_f di_f/dt \tag{18}$$

The instantaneous armature current I_a

$$v_a = R_a i_a + L_a di_a/dt + e_g \tag{18}$$

The motor back emf, which is also known as speed voltage:

$$e_g = K_v \omega i_f \tag{19}$$

The torque developed by the motor:

$$T_d = k_t i_f i_a \tag{20}$$

The torque developed must be equal to the load torque:

$$T_d = \frac{Jd\omega}{dt} + B\omega + T_L \tag{21}$$

Where,

ω = motor angular speed, or rotor angular frequency ,rad/s;

B=viscous friction, N-m/rad/s;

k_v = voltage constant, V/A-rad/s;

K_t = torque constant equal to the voltage constant;

L_a = armature circuit inductance, Henry;

L_f = field circuit inductance, Henry;

R_a = armature circuit resistance, ohm;

R_f = field circuit resistance; ohm;

T_L = load torque, N-m.

8. Results

A comparative study has been done in this section by adjusting certain features in the circuit, such as introducing a capacitor into the supply section for the

choppers. The observations were made through the PSIM simulation software dedicated for Power Electronics and Motor control.

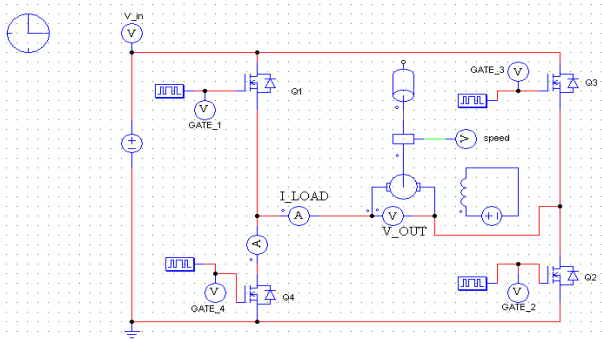

Fig. 8. Four quadrant (4Q) operation for Power control using separately excited Dc motor in PSIM without a input capacitor.

1. 4Q-Chopper Circuit without capacitor :

Simulation parameters [1] (rated values):

- Motor Terminal Voltage 220V
- Motor Output 0.5 Hp
- Motor Field Voltage 220V
- Motor Field Current 0.2 Amps
- Motor Rated Speed 1200 rpm
- Motor Armature resistance 2 Ohm
- Motor Field Resistance 540 Ohm

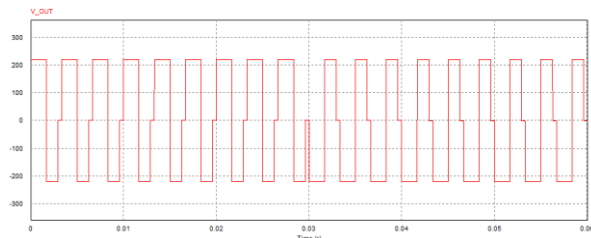

Fig.8.1. output voltage wave form.

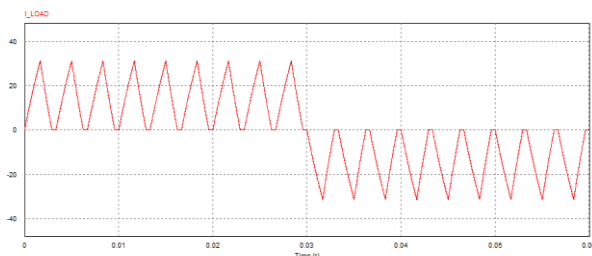

Fig.8.2. current wave form.

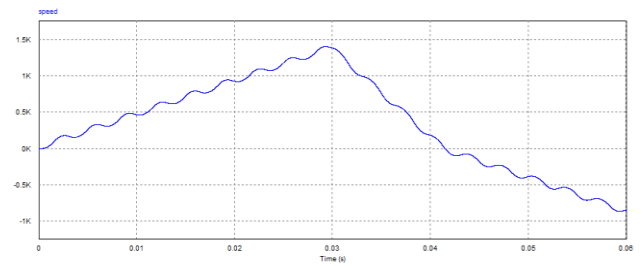

Fig.8.3. speed wave form.

2. 4Q-Chopper Circuit with Capacitor(Fig.9) :

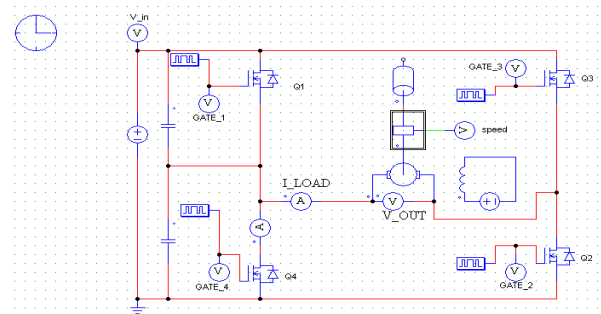

Fig.9. Four quadrant (4Q) operation for power control using Separately excited DC motor in PSIM with a input capacitor .

Simulation parameters remain the same. While results are being observed using PSIM.

9. Conclusion

Preference of the armature control method is high due to good speed regulation. Speed regulation can be done only up to rated speed or below rated speed. A comparative study of the Separately Excited DC motor concludes that without using input capacitor speed fluctuates up to the rated speed and current is discontinuous in nature whereas using input capacitors we can conclude that the speed regulation is very smooth and current becomes almost continuous. Thereby from the output waveforms, we can visualize the Forward Motoring action for duration of 0.03s and Reverse Motoring action for same duration of 0.03s. Hence Power ($P = V_a \cdot I_a$) control is achieved.

10. Future Scope

Field flux control is employed to achieve speed control above base speed. In a Separately excited DC motor, we need to vary field voltage as desired to control flux. In view of this we need to have closed loop control methods. It is achieved by employing an inner current control loop within an outer speed loop. For operation of a dc drive, inner current loop is employed to control torque and motor currents below a safe limit. In future

are looking forward to employ various closed loop control methods applied for DC drives and find their performances using PSIM. Further side by side employing Buck and Boost converters by various open loop and closed loop controlling techniques for DC drives and integrate them using PID ,Fuzzy and Neuro-Controllers.

References

1. Naveen R. Sharma, Ravishankar Kumar and N.G.Mishra, Simulation of Four quadrant Chopper using PSIM, in *World Journal of Science and technology* . 2(4) (2012) 70–74.
2. R. Krishnan, *Electric Motor Drives- Modeling, Analysis and Control*, 10th edn. (Prentice Hall, Upper Saddle River, NJ, 2001).
3. Muhammad H. Rashid, *Power Electronics- Circuits, Devices, and Applications*, 9th edn. (Springer-Verlag, New York, 2011).
4. Bimal K. Bose, *Modern Power Electronics and AC drives*, 1st edn.(Prentice Hall (P) Ltd.,New Delhi, 2011).
5. Magnus Hedlund, “*Design and Construction of Bidirectional DC-DC Converter for an EV Application*”, (<http://www.teknat.uu.se/student>, Feb, 2010).
6. N. Mohan, T.M. Undeland, W.P. Robbins, *Power Electronics: Converters, Applications and Design*, 3rd edn. (reprint by Wiley India(P) Ltd, New Delhi, 2007).
7. G.K. Dubey, *Power semiconductor controlled drives*, 1st edn. (Prentice Hall, Upper Saddle river, NJ, 1989).
8. G.K. Dubey, *Fundamentals of Electrical Drives*, 2nd edn. (Narosa Publishing House (P) Ltd, New Delhi,2001).
9. S.S. Raghuvanshi, K. Gupta, S.Manjrekar, D. Choudhary, Y.Mokhariwale, Analysis and Design of a Closed-Loop Converter Controlled DC drive, in *International Journal of Engineering Trends and Technology*. Volume-3, Issue-3 , (2012).
10. Texas instruments, Understanding Buck Power Stages in Switch mode Power Supplies-Application report, in Mixed signal Products(March,1999).
11. Alan Martin, Boost Converter Design Tips, in Field Applications Engineering, National semiconductors, (March, 2005).
12. K. Ogata, *Modern Control Engineering*, 4th edn. (PHI learning (P) Ltd, New Delhi, 2009).
13. K.A. Naik, P. Srikanth, Stability Enhancement of Dc Motor using IMC Tuned PID Controller, in *International Journal of Advanced Engineering Science and Technology*. Vol. No.4, Issue No.1.,(2011) 092-096.

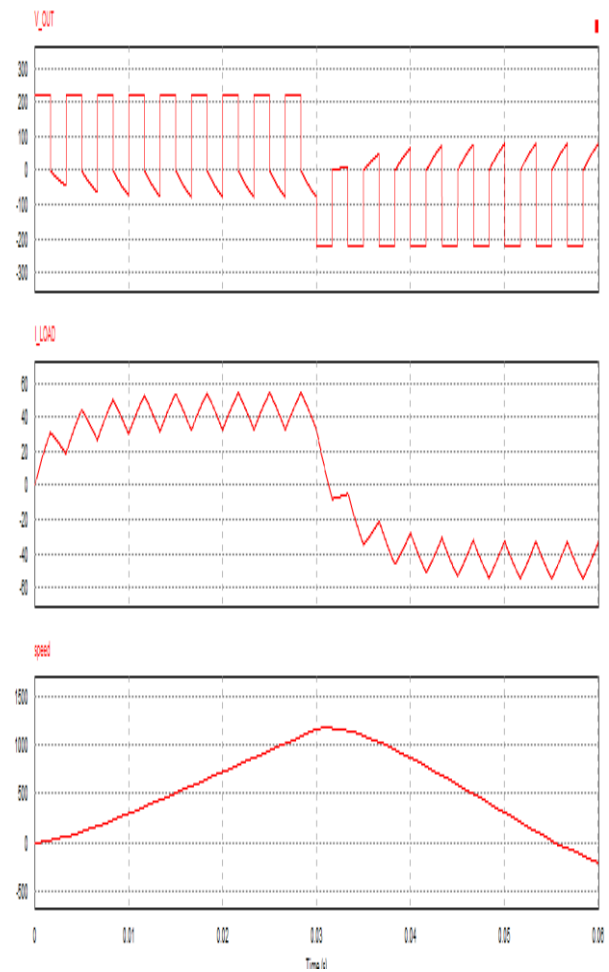

Fig.9.1. voltage, current, and speed wave form.