

Development and Application of On-Line Torque Telemetry System for Rolling Mill based on WIFI Signal Transmission and High Frequency Induction Power Supply

Jinliang Jia, Xiaoqiang Yan*

School of University of Science and Technology Beijing, Beijing, China

* yxqzhw@263.net

Abstract. For the rolling mill torque telemetry system, the battery power supply has a short duration, and the current supply by the collector ring can achieve long-term power supply, but it is difficult to achieve stable power supply for a long time due to limitations such as speed and wear. This paper designs a high-frequency induction power supply system to realize long-term stable power supply of sensors and signal transmitting modules on the measured axis. The WIFI signal transmission technology is used to realize the fast, efficient and stable wireless transmission of torque signals. The embedded programming of STM32F103 chip based on Cortex-M3 kernel architecture realizes the AD conversion, signal processing, WIFI transmitting and receiving control of torque signal. The system has been applied to the monitoring of main drive torque of many continuous rolling mills and achieved good results, which can replace expensive imported products.

Keywords: STM32F103 chip, Cortex-M3, high-frequency induction power supply system, WIFI signal transmission.

1. Introduction

With the continuous improvement of the production and quality of the rolling high strength thin strip, the rolling mill bears a greater load, and the main transmission electromechanical system accidents occur frequently. Especially in recent years, the torsional vibration problem of the continuous rolling mill is particularly prominent. Because of the lack of torque parameter data after the accident, it is very difficult for the accident analysis and the responsibility referee. Therefore, on-line monitoring of torsional vibration of main drive is an urgent problem.

The torque of the main drive system of rolling mill includes the rich information of the rolling process. The real-time monitoring of torque can help the field operators to accurately grasp the working condition of the main drive of the rolling mill. The on-line torque telemetry system has been used for many years in the field of steel rolling, mainly depending on the import from the United States. The system is expensive, complex installation and lagging behind service, which brings inconvenience to the use of the site. After years of research, University of Science and Technology Beijing has made great progress. The self-made torque on-line telemetry system has been successfully applied to the production site, and the running condition is good. The on-line telemetry system of rolling mill torque has been made domestically.

2. Overview

The real-time on-line monitoring of equipment state can provide reliable and useful data information for the production process, so as to ensure the safe and efficient operation of the equipment, therefore all countries in the world are actively engaged in the development of the on-line real-time monitoring system of the equipment state. In 1995, the University of Aachen in Germany developed data for measuring the torque of the upper and lower roller drive shafts [1]. In 1998, Andreas Asch, Wolfgang Hohn developed a new torque measuring device based on strain gage technology [2]. In 1999, the American Binsfeld engineering company launched TorqueTrak 9000, which is a fully digitized battery powered radio torque telemetry system. In 2002, the Binsfeld company developed a TorqueTrak Revolution torque on-line telemetry system to achieve non-contact induction power supply [3].

The torque monitoring technology of domestic rolling mill started relatively late. In 80s, the Mechanical Science Research Institute launched the analog torque telemeter[4].The rolling mill torque telemetry system developed by University of Science and Technology Beijing in 2000 has been identified by the Ministry of education and has been put into operation in dozens of heavy and medium plate mill nationwide. It provides a monitoring means for the scientific operation and potential of the equipment, and has achieved remarkable economic and social benefits[5].In 2009, the telemetry torque instrument designed by Jilin University based on Bluetooth technology was simulated theoretically[6].In 2017, the vibration signal acquisition instrument based on WIFI, designed by Tianjin University of Technology, carried out the theoretical research on the principle of WIFI wireless transmission. Through the optimization design of hardware and software, it is expected to improve the precision of signal acquisition and transmission efficiency[8].

To sum up, the development of the telemetry system from the analog torque to the digital torque telemetry system makes the signal transmission precision, anti-interference and reliability greatly improved. The stability of the high frequency induction power supply on the measured axis has become the focus and difficulty of the present research.

3. System Composition and Principle

3.1 System Composition.

The torque telemetry system of rolling mill is mainly composed of three parts.

- 1)Acquisition and processing module of torque signal;
- 2) WIFI wireless signal transmission module;
- 3) Wireless induction power supply module.

The overall structure of the torque telemetry system is shown in Fig 1.The static power supply loop is used as a primary coil of induction power supply for telemetry system.The rotating ring made of special ring and riveted on the coated copper as the secondary coil.Inductive power supply receiving circuit board, torque signal acquisition circuit board and WIFI transmitting module are embedded in the special ring.The main control unit is built-in the outer ring high frequency induction power supply circuit board and the torque signal WIFI receiving module.

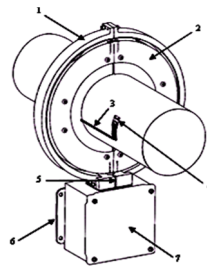

1.Static power supply ring;2. Revolving ring;3. A wire connecting a strain gauge and a rotating ring transmitter;4. Welded strain gage;5. System state indicator lamp;6. Flange for installation;7. Main control unit.

Fig.1 Component assembly diagram of the torque telemetry system.

3.2 Principle of Operation.

Firstly, the 350-ohm welded full bridge strain gauge is welded to the surface of the main motor output shaft of the rolling mill with a special welding machine (Fig. 2), so that the strain gauge and the axis are 45 degrees (Fig. 3). Then the torque size is:

$$M = \frac{0.2ED^3}{1 + \mu} \cdot \frac{U_o}{KU_i}$$

In the formula, The E is the elastic modulus of the measuring axis, the D is the diameter of the measured axis, the μ is the elastic modulus of the material, the K is the strain gauge Ksen, the U_i is the bridge voltage, the U_o is the output voltage of the strain gauge [9].



Fig.2 Welding position diagram of strain gauge.

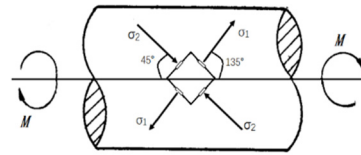

Fig.3 Stress state of measured axis.

After calibrating the output voltage signal of the whole bridge, the torque value of the measured shaft can be obtained.

Due to the rotation of the full bridge strain gages on the measured axle, the torque signal is transmitted to the main control unit by wireless way after the acquisition and processing of the torque signal.

The process of torque wireless signal transmission includes two parts: serial port to WIFI and WIFI to transmit each other. In the process of signal transmission, firstly, the voltage signal collected is connected with the WIFI module through the serial port of the single chip microcomputer to realize the signal transmission in the transparent transmission mode. In this mode, the module realizes the transparent transmission between the UART and the network, and realizes the data transfer between the universal serial device and the network equipment, and the data receiving of the module serial port automatically transfers the received data to the server that has been set. The advantage of serial port transparent transmission mode is that it can realize plug and play between UART interface and network communication, thus reducing the complexity of communication process to the greatest extent. This mode mainly implements the data of the signal transmission device to interact with a fixed server, and through a simple socket communication, the WIFI communication process is shown in Fig.4.

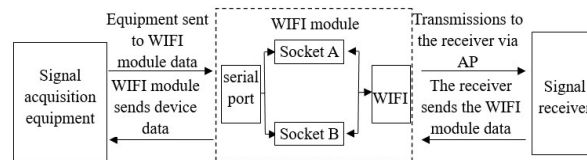

Fig.4 Diagram of WIFI communication process.

The long term power supply of the strain gage, signal processing module and the transmitting module on the measured rotation axis is a technical problem. The induction power supply is the use of the electromagnetic induction of the inner and outer loop coil to realize the power transmission[10]. The outer loop has high frequency magnetic field with high frequency alternating current. The inner ring uses air as magnetic medium to realize magnetic induction in the high frequency magnetic field and outer ring, thus producing stable high frequency alternating current. The high frequency AC voltage obtained by the inner loop coil is obtained by the depressurization and AC/DC conversion, and the required power supply voltage (DC5V) is obtained, and the inductive power supply is equivalent. The Equivalent circuit of inductive power supply is shown in Fig.5.

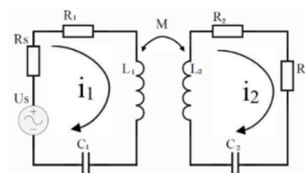

Fig.5 Equivalent circuit of inductive power supply.

4. System Design

4.1 Hardware Design.

The full bridge strain gage welded on the measured axis is subjected to torque, and the output of the bridge imbalance output is proportional to the torque size. After the amplification and filtering, the single chip microcomputer is input to A/D conversion, and the inner ring WIFI module is configured through the USART port. The WIFI module uses the transmission mode and the WIFI module in the main control unit to realize the wireless signal interaction. The final transmission to the signal processing unit. Signal processing unit and WIFI signal transmission are controlled by STM32 embedded programming based on Cortex-M3 kernel architecture. After the signal processing of the main control unit, the signal is converted into analog signal output, the shield line passes the signal to the network collector, and then connects to the computer through the network line. Finally, the computer on the rolling mill operating table shows the real time torque signal waveform and the spectrum diagram (Fig.11), and the flow chart of the system work flow chart is shown in Fig.6.

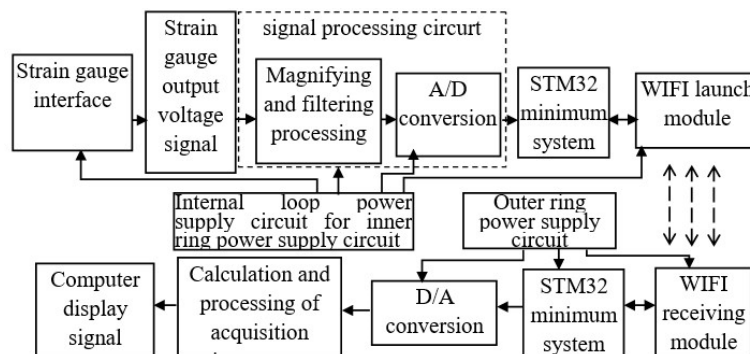
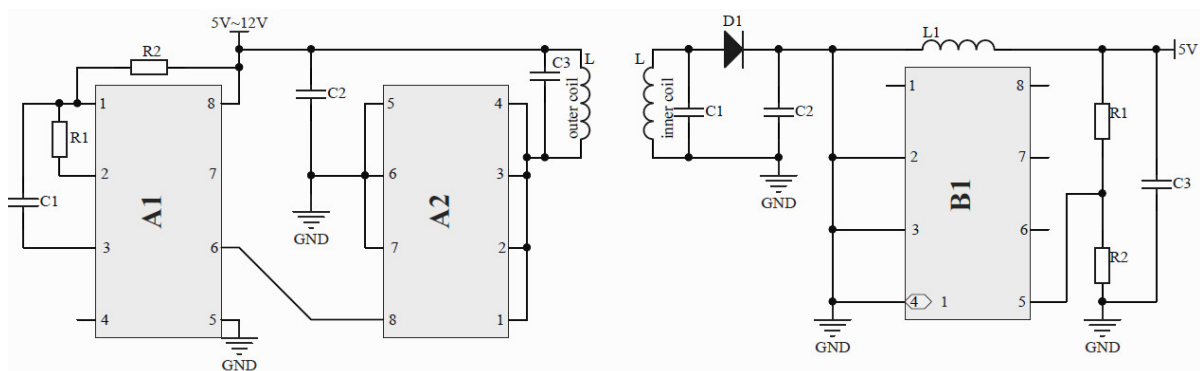

Fig.6 Workflow chart of system.

The outer loop high frequency alternating current of the induction power supply system uses A1 and A2 chip as the core circuit. Inner loop coil converts the inner loop circuit of the induction electric energy through the B1 chip to the required 5V/500mA DC power supply voltage through electromagnetic induction. The circuit schematic diagram is shown in Fig.7.



(a). Outer loop transmitting circuit schematic (b). Inner loop receiving circuit schematic

Fig.7 Schematic diagram of high frequency induction power supply.

A1 high frequency and high-power integrated circuit chip has the characteristics of small size and high output power. It can work in a high frequency range. A2 is responsible for radio transmission and real-time monitoring of the circuit. A1 can make a high reliable wireless power supply with only a few external components. The A2 chip is a high frequency and high-power output integrated circuit developed with the A1 chip, which can improve the conversion efficiency and enhance the output power. B1 is a radio transmission and receiving integrated circuit, which has the advantages of small

size and high output power. It can be used with various radio energy transmission schemes, and the circuit is easy to use. The pin functions of A1, A2 and B1 are shown in Table 1.

Table 1. Inductive power supply circuit of each chip pin function.

Pin number	Pin function		
	XKT412	XKT335	T3168
1	VD/Voltage detection	OUT/Output	NC/Null
2	MFA/Multifunction adjustment	OUT/Output	IN/Input
3	FT/Frequency tuning	OUT/Output	OUT/Output
4	WL/Power enhancement	OUT/Output	GND/Ground
5	GND/Ground	GND/Ground	VA/Output voltage regulation sampling
6	OUT/Output	GND/Ground	NC/Null
7	TD/Power drive	GND/Ground	O/F/Output control enabled end
8	VDD/Power cathode	IN/Power input	NC/Null

The signal acquisition and processing module is based on the STM32 MCU as an embedded microprocessor. It is responsible for the allocation, scheduling and control of all the hardware and software of the whole system, and realizes the control of signal acquisition, processing, digital mode conversion and wireless transmission. The STM32F103RCT6 MCU is used as the core, and some peripheral circuits are designed to realize the operation of amplification, A/D conversion, numerical transformation and program control for the output signal of strain gage. STM32F103RCT6 microcontroller has rich functions, including analog to digital conversion and digital analog conversion module, with a variety of high-speed communication ports, including CAN, USB, USART and SPI and other communication interfaces, with flexible static storage controller, advanced interruption processing capability, to meet the system for the acquisition of signal processing requirements.

The wireless signal transmission module realizes the point to point connection by using serial port to WIFI module based on RTL8711. Realtek RTL8711 chip is integrated in high chip, integrated with antenna switch, power management converter, ARM Cortex M3 MCU, 802.11n Wireless network controller. It also provides some configurable peripherals such as GPIO. Realtek 8710 chip itself has built-in storage controller including ROM and SRAM. MCU can access storage controllers through the IBus, DBus, and AHB interfaces, all of which can access ROM or RAM units, and support two modes of work: transmission mode, command mode. In the transmission mode, the transparent data transmission between UART interface and network is realized by configuring the corresponding parameters. The principle of WIFI module is shown in Fig.8.

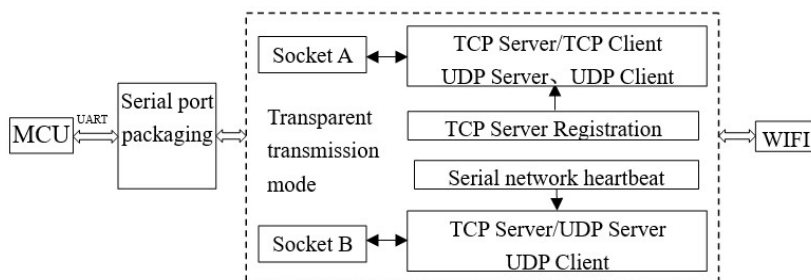

Fig.8 WIFI module transparent transmission mode communication schematic.

Wireless signal transmission antenna uses USR-ANT2G5G-S001 embedded PIFA antenna, it is a 2.4G/5G dual-band Wi-Fi antenna with high efficiency and fast integration design. It is applicable to national WIFI or ISM band applications, supports 802.11a/b/g/n wireless standards, supports TCP, UDP, ICMP, IPv4, ARP, IGMP, and PPPoE protocols, and provides flexible installation methods to shorten industrial design and product development cycles.

The main control unit sends the torque signal through the processing unit to the collector for collection, and the collector connects to the computer through the network line to display the real-time torque signal. Each channel of the collector adopts independent 24bitsADC, which has high noise signal ratio, and ensures synchronous acquisition of each channel. The synchronization of all channels can also be guaranteed when multiple instruments are set up. The collector has built-in power supply module, bridge voltage supply, signal amplification, voltage stabilizing circuit and so on, which can collect signal processing.

4.2 Software Design.

The system software design mainly realizes the following functions: serial port configuration USRT-WIFI module and work mode; A/D conversion control; WIFI sending and receiving data; data display, analysis and preservation.

The task flow of the system WIFI communication process is shown in Fig.9. The single chip sends the acquisition signal to the WIFI transmitting module through the serial port after processing, and the WIFI receiving module sends the request receiving command to the transmitting module. The transmitter sends the data of the serial port to the receiver and completes the WIFI data communication.

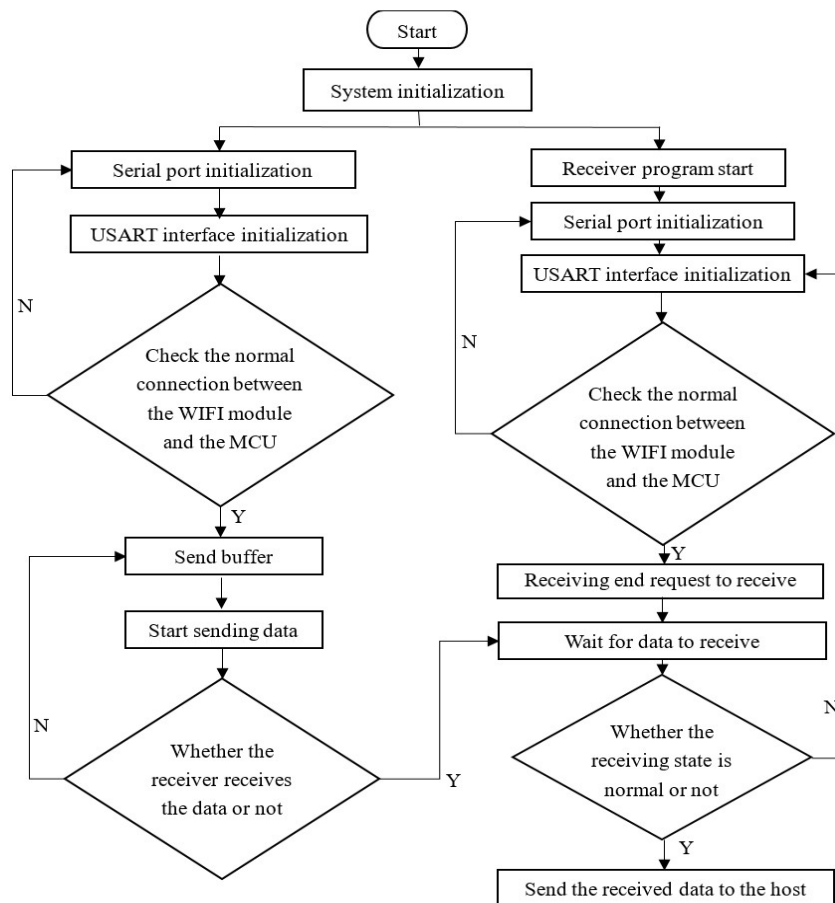

Fig.9 WIFI module data communication task flow chart.

The rolling mill operating table has the software of engineering test and analysis, and the torque data is processed to realize the function of real-time acquisition, display, preservation and analysis of

the signal. Fig.10 is the software main interface, which mainly displays the real time state waveform of the signal. By setting it, the time domain, frequency domain, time domain + frequency domain curve can be displayed separately, and the data statistics form and single data histogram can be displayed directly. It can change the way of data acquisition, sampling frequency, storage time and data storage directory according to needs. Data analysis provides functions such as time domain analysis, frequency domain analysis, correlation analysis, 3D waterfall analysis and general trend analysis.

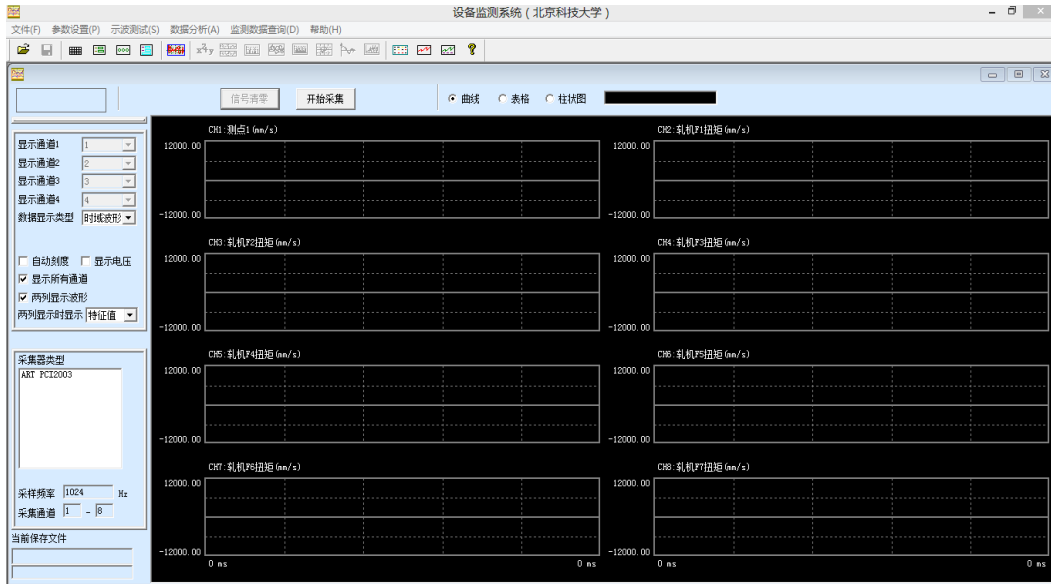
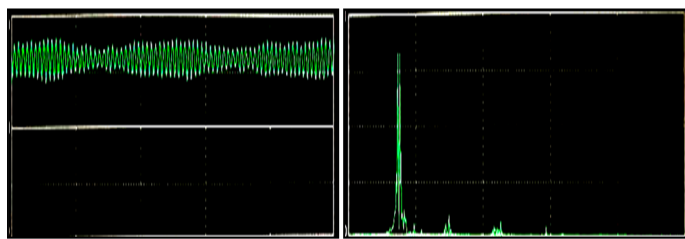

Fig.10 Software main interface chart.

5. Field Measurement Application.

The developed torque online telemetry system has been installed and applied on the output shaft of the main drive motor of several tandem mills, as shown in Fig.11.



a. Field torque telemetry device photo b. Torque signal waveform and spectrum photograph

Fig.11 Torque signal time domain analysis diagram.

Through the real-time monitoring of the torque size and frequency spectrum, the rolling mill can be operated scientifically to improve the operation rate, safety and equipment potential of the rolling mill. By setting the safety threshold, the alarm can be sent out quickly when the torque signal appears abnormal change, which can remind the operator to make the adjustment in time to avoid causing large production accidents.

6. Conclusion

A torque on-line monitoring system is developed. The software and hardware of wireless transmission of torque signal and high frequency induction power supply are designed and manufactured. The system runs well after debugging. The problem of long-term stable supply of sensors, transmitting modules and signal processing units on the measured rotating shaft is solved successfully by using high frequency induction power supply. The application of WIFI wireless signal transmission solves the problem of wireless transmission of torque signals and has strong anti-interference ability. The system has been used in more than 30 sets of hot strip mill, cold rolling mill, leveler machine, light leveler machine and straightener machine. It can replace the imported products directly. It has achieved good use effect and has broad application and promotion prospects.

Acknowledgments

This work was financially supported by "12th five-year" national science and technology support plan, "precision strip steel product quality optimization and key equipment research and development".

References

- [1]. Jorg Weidemann, William C. White, Gary L. Furst. Machine monitoring for heavy beam mills-innovations at Nucor-Yamato Steel. *Iron and Steel Engineer* 1995, No.1:43~49.
- [2]. Asch A, Hohn W. Monitoring System for Roll Stand Drives using Strain Gage Technology. *Proceedings of the 9th IFAC Symposium on Automation in Mining, Mineral and Metal Processing*. IFAC International Federation of Automatic Control 1998:159~164.
- [3]. Binsfeld Engineering Inc. Torque and power monitoring system [J/OL]. Binsfeld Engineering Inc (2018-05-27) [2018-06-10]. <http://www.binsfeld.com>.
- [4]. Yan X Q, Cui X B. Torque Telemetering System of Main Drive System for Rolling Mill Based on nRF9E5. [J]. *Microcomputer Information*, 2007, 29(9-1):107-108.
- [5]. Yan Xiaoqiang, Yuan Xiaojiang, Chen Wei et al. On-line condition monitoring system for large rolling mill. [J]. *Metallurgical Industry Automation*, 2002, 02:59-61.
- [6]. Lv Bin. Design and Research of Telemetry Torquemeter Based on Bluetooth Technology. [D]. Changchun: Jilin University, 2009.
- [7]. Zhang Wei, Liu Anzhong, Xiao Lingjun. Real-time monitoring of the main drive torque of the rough mill by means of remote measurement [J]. *Journal of wuhan university of science and technology*. 2010, 33(04):423-426.
- [8]. Tai Xuefeng. Research and implementation of vibration signal acquisition instrument based on WIFI. [D]. Tianjin: Tianjin University, 2017.
- [9]. Wang YongLian, *Mechanics of materials*. [M]. Beijing: China Machine Press, 2017.
- [10]. Shu Xujian, Zhang Bo. Energy Model and Characteristic Analysis for Inductively Coupled Power Transfer System. [J]. *Automation of electric power system*. 2017, 41(02):28-32.