

Discussion of the Importance of IGBT in Variable-Frequency Drive

Jiangping Nan ^a, Zhao Wang ^b

School of Xi'an Traffic Engineering Institute, XI'AN 710300, China.

^ananjiangping@163.com, ^b420475703@qq.com

Abstract. In the modern industry, Variable-Frequency Drives are used frequently. With the emergence of fully-controlled power electronic devices, AC-DC-AC Variable-Frequency Drives quickly occupy the market with its small harmonics and good stability. The main circuit of the Variable-frequency Drive mainly includes a rectification filter module and a Variable-Frequency Drive module. The inverter module plays an important role in the Variable-Frequency Drive, and the most important switching device used in the inverter module is the IGBT.

Keywords: Variable-frequency Drive; Inverter module; IGBT.

1. Introduction

Variable-Frequency Drive (VFD) technology has a tight relationship with electricity and electronics, including semiconductor switch element, VFD topology, control and simulation technology, control hardware and the improvement of firmware etc. In 1960s, the invention of high-power thyristor makes it possible for variable frequency adjustment. In a thyristor converter, capacitors using for mutual shutdown require high voltage and high capacity. Thus, they are pricy. Also, under different load currents, the conditions of shutdown are different, affecting their reliability. Besides, the output voltage and current have a large harmonic component. So, even though thyristor made it possible for frequency adjustment, realized the wish that people have on frequency adjust in the recent hundred years, it did not reach the level where the mass application is possible. In 1970s, the power transistor came out, letting frequency adjustment practical. It started to become popular in 1980s. Power transistor actually consists of two or more transistors, a composite transistor (Darlington Tube), also known as giant transistor (GTR) or bipolar transistor (BJT). In late 1980s, the invention of insulated gate bipolar transistor makes VFD improve a lot in many aspects.

According to the latest investigation report, the sale of all kinds of IGBT components will recover in certain degree. In 2014, it slows down a little. After the economy recovered and stabilized, it started grow steadily. Though in 2013 the growth trend of IGBT decreased a little, with the improvement of the technology, its future was optimistic. We can say that IGBT tube builds a foundation for the application and improvement of VFD.

2. Variable-frequency Drive

Variable-Frequency Drive (VFD), also called variable frequency adjustment component, is a power control unit using the shutdown function of power semiconductor device to transform power supply frequency to another frequency. It achieves the alternating asynchronous motor's soft start, variable frequency adjustment, improvement of operation accuracy, changing power factor, and the feature of overcurrent/overvoltage/overload protection. VFD is one kind of adjustable speed drive system, using variable frequency drive technology to change the frequency and amplitude of working voltage of alternating motor, to smoothly control the speed and torque of alternating motor. The most common alternation convertor's input and output is alternating electricity.

The energy saving aspect mainly shows in the application of fan and water pump. To ensure the reliability of production, all kinds of producing machines are designed with certain amount of surplus. When the electric motor cannot run at full load, besides the requirement of power drive, the extra torque increases the consumption of active power, causing waste of power energy. Traditional equipment like fans and pump adjust wind supply and water supply through adjusting the bezel of

inlet or outlet. Its output power is huge. Also, huge amount of energy wasted in the process of the interruption of inlet and outlet. When using variable frequency adjustment, if the request of flow decreases, it can fulfil the request by lowering the speed of pumps or fans.

The purpose of VFD for electric motor is to adjust speed, and to lower the startup electric current. To create variable voltage and frequency, this equipment needs to change the alternating current (AC) into direct current (DC). This process is called current adjustment. The component of transforming DC into AC is called inverter. The regular inverter is to alter DC into certain frequent and certain voltage. For frequency adjustable, voltage adjustable inverter, the output of VFD is mimicking sine wave, mainly for the speed adjustment of three phase asynchronous motor, is also called variable frequency adjustment component. For variable frequency inverter used in the inspecting equipment when requiring a good wave shape, it has to adjust the wave shape and be able to output sine wave, is called variable frequency power supply. The price of regular variable frequency power supply is 15 to 20 times of VFD's price. Because the main equipment for creating variable voltage and frequency is called 'inverter', this product itself is named as 'inverter'.

Before the VFD appears, to adjust the speed of electric motor, we need DC motor or inner coupling VS electric motor. During its runner, it uses coupling component to decrease the actual running speed. VFD simplifies the above work, decreases the size of equipment, significantly lowers repair rate. However, there are high frequency switching signal in the power cord of VFD, causing electromagnetic interference. The power factor of the input side of VFD is bad, can cause harmonic wave of power supply side.

The applicable of VFD is broad. It is from small appliances to large mine grinders and compressors. About 1/3 of global energy is consumed during the driving of fix speed centrifugal pump, fans and motors of compressors. And the market share of VFD is not big. The significant improvement of energy efficiency is one of the main reasons.

3. IGBT

IGBT is short for Insulated Gate Bipolar Transistor. It is a device composed by MOSFET bipolar transistor. The input polarity is MOSFET, while output polarity is PNP GTR. IGBT combines the advantages from both of them. Its main part is the same with GTR, which contains Collector (C) and Emitter (E). Its control electrode is identical with MOSFET, which is insulated grid structure; also know as Grid (G), as it is shown in Fig. 1. It possesses the strength of low driving power of MOSFET device and fast speed of switch, and it takes advantage of low saturation voltage with high volume of bipolar transistor. IGBT's frequency characteristic lies in between of MOSFET and power transistor. It functions normal under 10s kHz frequency range. In modern power electronic technology, it has been applied comprehensively, which dominates in high, medium power applications with high frequencies.

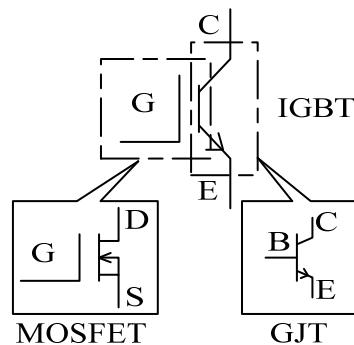

Fig. 1 IGBT Structure Features

By adding positive driving voltage between IGBT's grid and emitter, MOSFET becomes breakover. In such case, transistor could be conducted under the low resistance state of PNP GTR

and base. If the voltage between IGBT's grid and emitter is zero, MOSFET would cut off the electricity supply of PNP transistor base. Same as MOSFET, IGBT is also a voltage control device. There is hardly any consumed power when comes to over 10V DC voltage between grid-emitter and uA level of leakage current passing through.

lower voltage control power consumption, easy circuit control, high-pressure resistance, and high current withstand, etc. many semiconductor manufactures keeps developing large volume of current, high speed, low voltage, high reliability, and lost cost technology of IGBT. New progress has been made by research and development by utilizing technology under 1 um.

As one of the crucial high power main current device of power electronics, IGBT has been widely applied to fields like household appliances, transportation, power engineering, renewable energy sources, and smart power grids. From the perspective of industrial application, it can be applied into transportation control, power conversion, industrial motors, uninterrupted power system, wind power, solar equipment, and automatic Variable-Frequency Drive. In consumer electronics, IGBT could be used for household appliances, cameras and mobile phones.

4. Relationship between IGBT and Variable-frequency Drive

Comparing to usual AD-DC-AC Variable-frequency Drive, its main circuit includes rectifier, filter, and inverter circuit, among which two parts of rectifier and filter circuit are to replace the three-phase (or single-phase) alternating voltage of the power supply with a stable DC voltage. The circuit structure has its own particularity as high DC voltage after rectifier, and is not allowed to reduce.

Inverter circuit structure is consisted of V1 – V6 switch parts in Fig. 2, which is called Inverter Bridge. The functionality is to convert DC voltage to three-phase alternating voltage with adjustable frequency and voltage. Currently the most common switch parts used in small and medium capacity Variable-Frequency Drive is IGBT. Inverter circuit's actual waveform of output voltage is the high frequency and high voltage pulse series after SPWM modulation. As it shows in Fig. b), all pulse amplitude equals to DC voltage U_D . As for the macro effect, it is equivalent to sine waves with Fig. c). During the analysis, it is common to regard the output line voltage of inverter circuit as sine voltage.

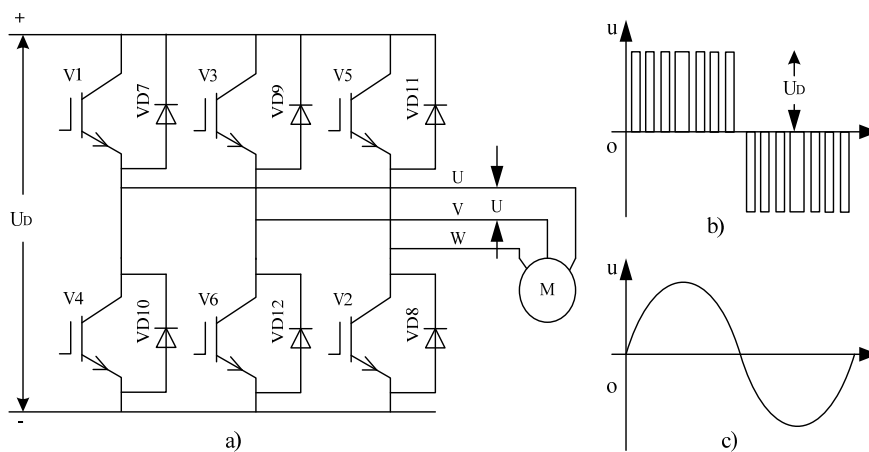

a) Inverter circuit b) Actual waveform of output voltage
c) Equivalent waveform of output voltage

Fig.2 Inverter circuit structure

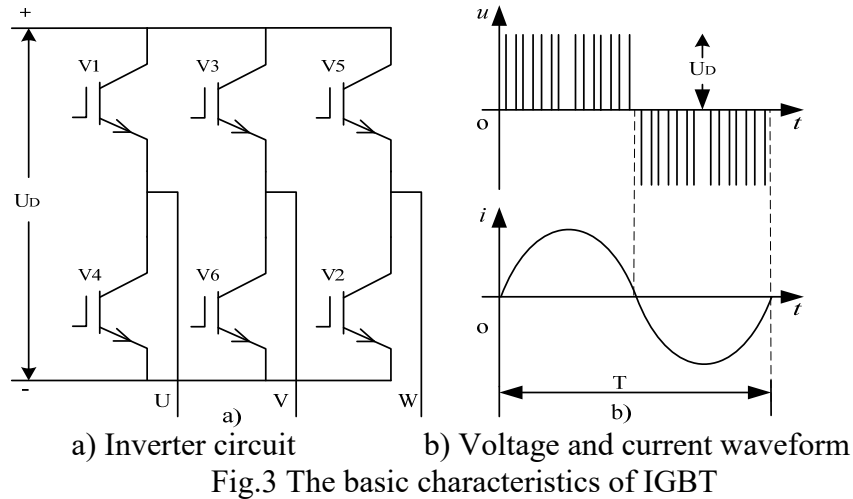

As shown in Fig.3, the key features of inverter circuit, which uses IGBT as the inverter device, are as below:

- (1) High carrier frequency: most of the converters' carrier frequency is adjustable within the range of 3 ~ 15 kHz. Its voltage waveform shows as the upper parts of Fig. b.
- (2) Great improvement of current waveform: higher carrier frequency results in a reduced harmonic wave component of the current. Current waveform is very close to sine wave, just like the bottom part of Fig. b. Therefore, the electromagnetic noise decreases, while the torque of electromotor increases.
- (3) Instant power outage would be non-stop: It is because of extremely small current. After the power outage, grid control voltage attenuates slowly. IGBT would not enter into zoom state immediately. Therefore, after sudden power outage or inverter tripped after false operation, it allows for automatic reclosing, and would not be tripped again, which enhanced self-processing capability to common faults.

We could say that IGBT has laid foundation for the rapid popularization and further improvement of variable frequency speed. It has been built into different modules, such as double pipes module in Fig. a, and six pipes module in Fig. b in Fig. 4 below.

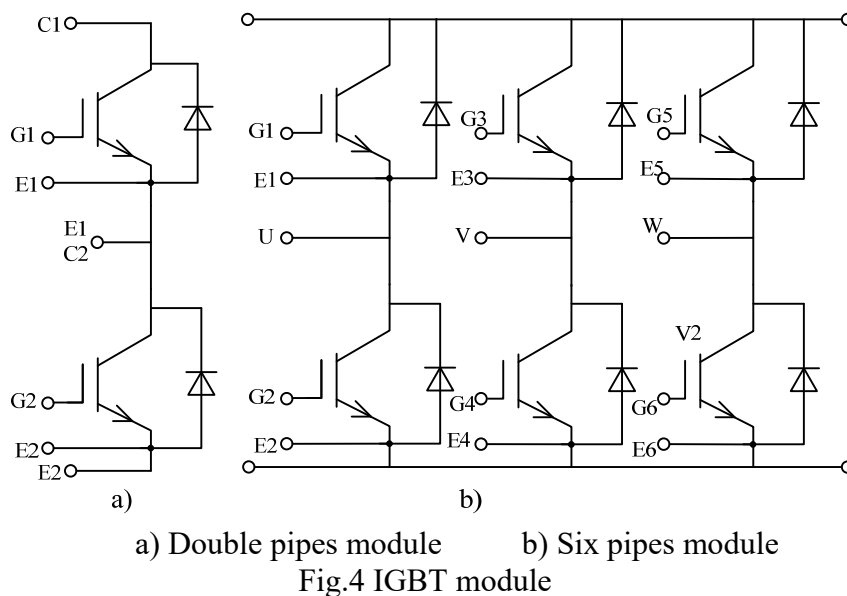

5. IGBT Partner in Variable-frequency Drive and Notice When using IGBT

5.1 Partner of IGBT

The partner of IGBT in VFD inverts circuit—reverses diode. In the invert bridge, next to every invert tube, it has to reverse parallel a diode, as shown in diagram 5 VD7-VD10.

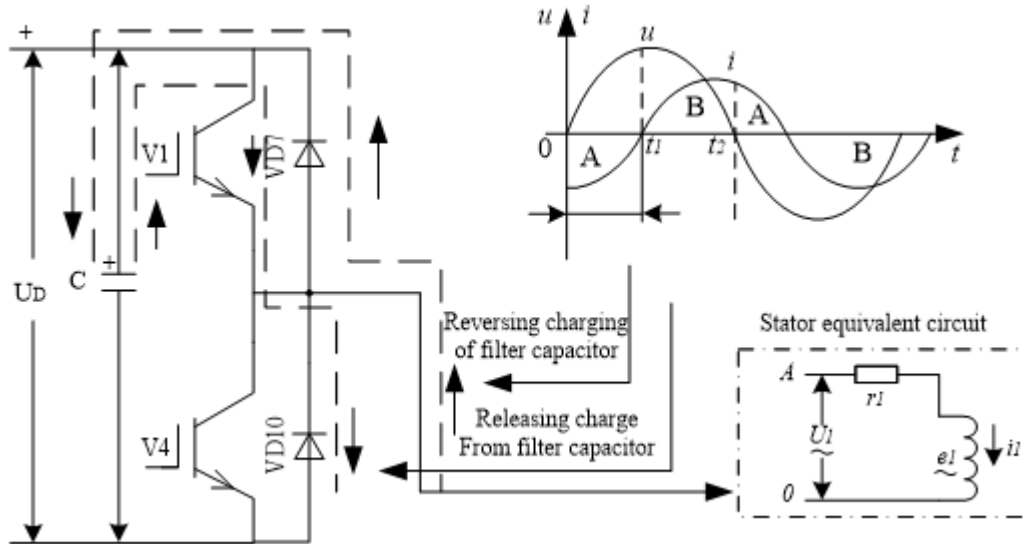

Fig.5 The effect of anti-parallel diodes in inverter bridges

Using a bridge arm as an example, it has the following functions:

Because the equivalent circuit of stator winding of asynchronous motor is resistance and inductance circuit. The changing of electric circuit falls behind voltage. When the direction of current I and voltage U , it is the self-sensing EMF (anti-EMF) is working to overcome the voltage of power supply (magnetic field work). The current here will flow into DC circuit through anti-parallel diode. Assuming no anti-parallel diode, it is single direction in the invert tube. The current has no way to pass, so the waves shape of electricity changes.

When the directions of current I and voltage U are the same, it is the voltage of power supply overcome self-sensing EMF in doing work (power supply work). The current here is that the filter capacitor discharges to the motor.

5.2 The Precautions of IGBT During Usage in VFD

1. When VFD in the pulse width adjustment, it adopts the ways of bipolar modulation. The characteristics of bipolar modulation are the triangle wave is bipolar. The pulse after the bipolar adjustment is also bipolar. But the line voltage pulse after composition is unipolar. In the process of adjustment of bipolar, the two up and down IGBT tube on the same bridge arm are rotating in alternating. Each IGBT tube takes time from saturation state to cutoff state.

In the process of alternating conduction, the original IGBT does not completely cutoff. And, another IGBT begin to pass. It will certainly cause the phenomenon of two IGBT tube pass at the same time.

To prevent direct pass, a dead zone must be left between a cutoff order of a IGBT tube and the pass order of another IGBT tube. The time interval of dead zone must longer than the time of cutoff of IGBT tube.

2. When the load frequency of VFD higher, the current leakage through distributed capacitor increases. The current leakage will go through IGBT. It will increase the burden of IGBT tube, decreases the ability of anti-parallel bright outputting electric current.

Each state switch of IGBT tube, it will have waste of switching and lose some power. If the load frequency becomes higher, the switching times of IGBT tube increases, the waste of switching is more. The waste of switching will lead to the heat of IGBT tube.

6. Conclusion

Small device makes a big difference. Even though IGBT is a small device, its effect is significantly important in Variable-Frequency Drive. IGBT elevates carrier frequency, improves current waveform of converter, increases torque of the electronic motor, and would not stop during converter's sudden power outage, which strengthened self-processing capability to common faults. We would tell that IGBT has laid foundation for the rapid popularization and further improvement of variable frequency speed and saved energy. It improves economic performance through various aspects, and provides fundamentality for the creative synergy of the enterprises.

References

- [1]. Yanbin Zhang: Application Tutorial of Variable-Frequency Drive (2nd Edition) (M). Beijing: China Machine Press, 2018: 21-22.
- [2]. Yuguang Hou: Brief Analysis of Technical Theories and Application to High Voltage Converter Power Unit (J). Value Engineering, 2018.15.
- [3]. Wei Chen: Brief Analysis of Variable-Frequency Drive's Principles, Maintenance, and Application (J). XINJIANG YOUSE JINSHU, 2018. S1.
- [4]. Wu Zhu: IGBT-Based Three-Level Converter Impairment Analysis and Calculation (J). High Power Converter Technology, 2017.5.