

Effects of Environment on Compressive Properties of Laminated Composites Containing a Central Hole

Hongliang Tuo ^a, Zhixian Lu and Xiaoping Ma

School of Aeronautics, Northwestern Polytechnical University, Xi ' an 710072, P.R.China

^ahongliangtuo@qq.com

Keywords: Composite, Compressive, Hygrothermal, Low temperature, Moisture

Abstract. This paper studies the effects of environmental factors on compressive properties of laminated composites containing a circle hole. compressive tests were conducted on three types of specimens that are exposed to low temperature, room temperature and hygrothermal environment respectively. The tests were carried out according to the ASTM D 6484. The results of moisture absorption tests indicated that the saturated moisture content of the specimens was around 0.7%. Compressive tests showed that the strength and stiffness increased with the content of 0° fiber, the strength and stiffness increased in low temperature environment and decreased in hygrothermal environment.

1. Introduction

Advanced composites have been widely used in aerospace, sports, medical engineering and energy industries due to their high strength/weight ratios and stiffness/weight ratios [1]. During the wide range of applications they have to be faced with different working environment conditions. But they are very susceptible to the environment conditions, so it is essential to have a detailed understanding on it to help the design of composite structures.

Many investigations indicate that composite materials are susceptible to moisture absorption. Many of their main properties, including coefficient of thermal expansion, modulus, glass transition temperature and viscoelastic behavior can change significantly after exposure to moisture [2, 3]. During the moisture absorption, physical changes such as micro-cracks propagation and swelling, as well as chemical changes such as hydrolysis and chemical scission increase, which can degrade properties of the materials [4-6]. The interface between fiber and matrix can also easily influenced by moisture absorption because matrix is easy to absorb water which leads to volume expansion, while carbon is almost non-absorbent, so that the resin's swelling generates stress and can cause interface debonding [7, 8]. In addition, water could interrupt the chemical bonding of the matrix or the interface, and could change the network structure of the matrix, hereby degrading material performance [9, 10]. The high temperature is another important factor leading the degradation of mechanical properties [11, 12]. Rui-Hua Hu's study indicates tensile strength of composite laminate severely decreased when exposed to hygrothermal condition [13]. Zhuan Quanwei investigates compressive strength of open hole laminate under high temperature [14]. Peng Lei suggested that the tensile and compressive strength and stiffness of open hole laminates decrease in hygrothermal conditions [15].

The widely applications of composite under low temperature condition promote the research of cryogenic mechanical properties. According to the recent studies, the strength and stiffness will be affected under low temperature. Many researchers present different views on this subject. Under low temperature condition micro-cracks can grow in the composite matrix due to the different coefficients of thermal expansion between the fiber and matrix and between different angle layers. As a result, this structural damage gives rise to the degradation of mechanical properties in the structures. [16–17].

The researches about composite mechanical properties under hygrothermal and low temperature condition during recent years mainly depend on laminates. Open hole is the commons shape of composite structure. The fibers were partly cut down by the open hole and will lead the stress

concentration, which has significant influence on the mechanical properties. Fewer papers have been published on the effect of environment factors on mechanical performance of open hole laminates.

The main objective of this investigation is to study the effects of environment conditions on mechanical properties of open hole laminates by using test methods and further discuss and analysis the results.

2. Experimental methods

2.1 Specimens and environment.

Specimen material was CCF300/BA9916 carbon fiber reinforced epoxy prepreg. Both tensile and compressive specimens were included with the geometry size 300×36×2.5mm as shown in Fig 1. Table 1 shows the specific lay-up of the laminates.

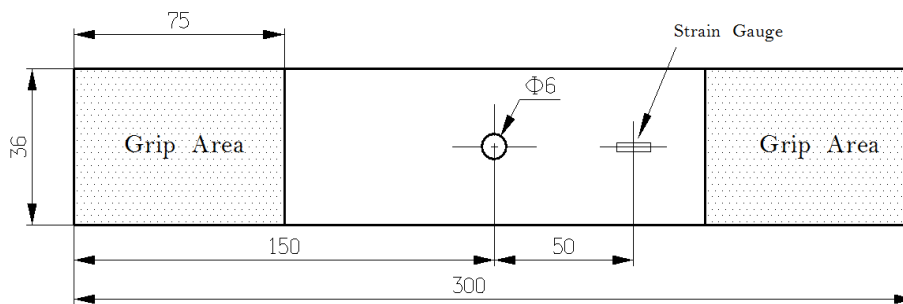

Fig. 1. Specimen geometry (all dimensions in mm).

Table 1 Lay-up of laminates.

Lay-up type	Lau-up ratio(0 ⁰ /45 ⁰ /90 ⁰)	Stacking sequence
A	30/60/10	[45/-45/90/45/-45/0/0/45/-45/0] _s
B	40/50/10	[45/-45/90/0/-45/0/0/45/-45/0] _s
C	50/40/10	[45/-45/0/0/-45/0/0/45/-45/0] _s

Three types of environment conditions were considered in this study:(a) low temperature condition: the specimens were stored and tested under -60 ° environment;(b) ambient condition: the specimens were exposed to room temperature;(c) hygrothermal: the specimens were immersed on the condition of 70 ° and 85% humidity until reaching a saturated moisture content.

2.2 Moisture absorption tests

Moisture absorption tests were conducted according to Chinese standard HB 7401-96 to investigate the changes in weight of the specimens by the environmental cabinet LSH-100CH. The weight equipment is PTT-A300 with the precision of 1mg. The specimens were stored in an environmental cabinet at 70 °C and 85% humidity, weighted and recorded every 24 hours until the change in weight calculated by Eq.(1) was less than 0.02%. The water gain percentage is calculated by the Eq.(2).

$$\left| \frac{W_i - W_0}{W_0} - \frac{W_{i-1} - W_0}{W_0} \right| < 0.02\% \quad (1)$$

$$M_t = \frac{W_t - W_0}{W_0} \times 100\% \quad (2)$$

Where W_t is the wet weight and W_0 is the dry weight of the specimen.

2.3 Open hole compressive tests

The tests were conducted according to the ASTM D 6484[18] under each environment condition. In the case of each condition, three types of stacking sequences were included with six specimens each. All specimens were loaded quasistatically in compression, in stroke control at a rate of 0.02 mm/s by MTS 810. The stiffness calculated by the signal was collected by the strain gauge. The test fixture was

designed to prevent the instability of the specimens. The parameters of the fixture did not allow to measure the hole deformation data.

3. Results and discussion

3.1 Moisture absorption

Fig. 2 shows the variation of moisture absorption for a type laminate as a function of time. From the figure it is clear that the rate of moisture absorption was high within 200h, subsequently dropped, and reached the equilibrium state after 1200 hours. The saturated moisture content of three types specimens is presented in Table 2. From the table we can know that the laminate type does not affect the saturated moisture content.

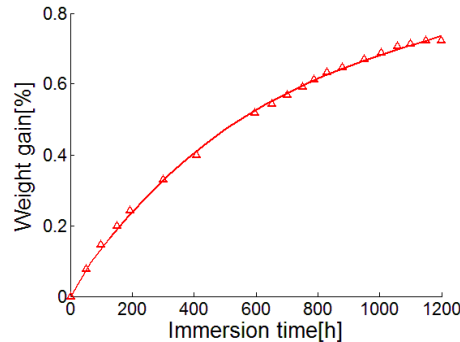

Fig. 2. Moisture absorption curve of A-type lay-up specimen.

Table 2 Saturated moisture content with different lay-up.

Lay-up type	Immersion time(h)	Saturated moisture content (%)
A	1200	0.728
B	1200	0.731
C	1200	0.723

3.2 Static open hole compressive tests

Fig 3 shows OHC strength test results for the three types of specimen according to environment. As shown in Fig 3(a), the tensile strength of A, B, C type specimen increased in turn under each condition. As revealed in Fig 3(b), strength under low temperature was higher than strength under room temperature, and strength under room temperature was higher than strength under hygrothermal conditions. The values are listed in Table 3.

OHC stiffness tests in different environment for different types of specimens are shown in Fig 4. The stiffness of A, B and C type specimens increased in turn under each condition. Fig 4(b) shows where stiffness in room temperature was lower than stiffness in low temperature and higher than stiffness in hygrothermal condition. Table 4 presents the stiffness values.

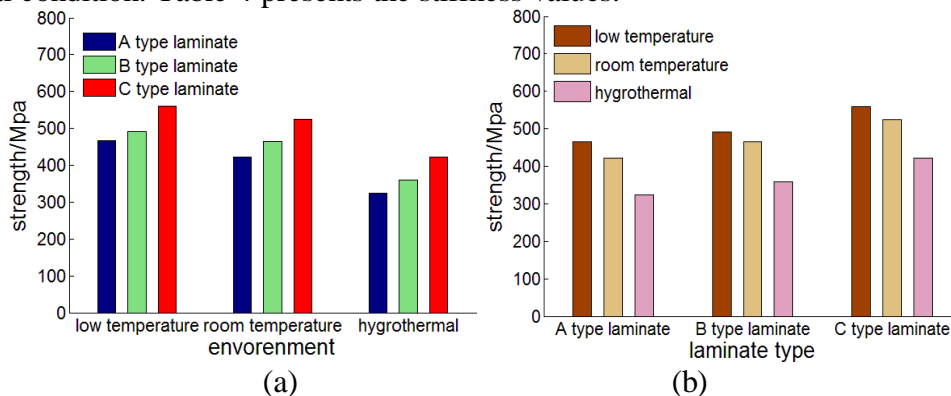

Fig 3 Compressive strength vs environment and laminate type.

Table 3 Strength of OHC specimens.

Lay-up type	Room temperature(MPa)	Low temperature(MPa)	Strength increase (%)	Hygrothermal (MPa)	Strength reduction (%)
A	423.10	466.00	10.14	324.77	-23.24
B	465.36	492.00	5.72	359.35	-22.78
C	526.20	560.00	6.42	422.04	-19.80

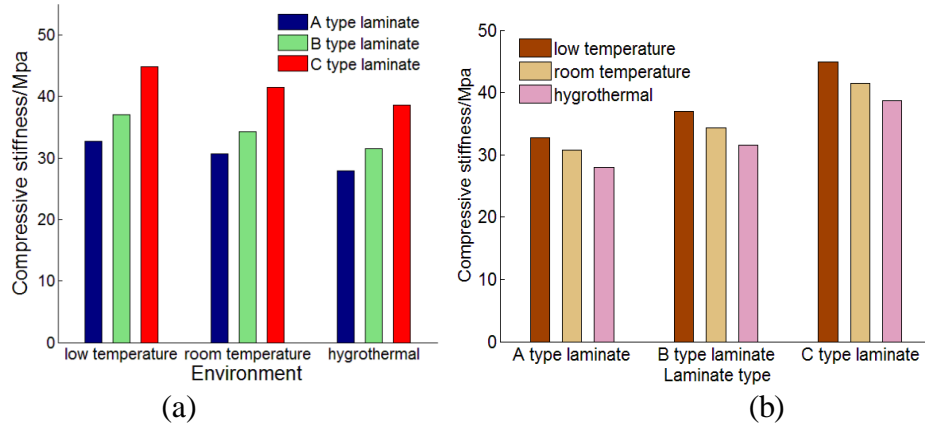

Fig 4 Compressive stiffness vs environment and laminate type.

Table 4 Stiffness of OHC specimens.

Lay-up type	Room temperature (GPa)	Low temperature (GPa)	Stiffness Increase (%)	Hygrothermal (MPa)	Stiffness reduction (%)
A	30.74	32.76	6.57	27.92	-9.18
B	34.34	37.01	7.78	31.54	-8.15
C	41.44	44.88	8.31	38.65	-6.73

To the room temperature condition, when 0° fiber content increased from 30% to 40%, the compressive strength increased 9.9% and the stiffness increased 11.7%, from 30% to 50%, the strength increase d 24.3% and the stiffness increased 34.8%.The similar conclusion can be drawn for low temperature condition and hygrothermal condition. This phenomena proves that the content of 0° fiber influence the strength and stiffness significantly.

Under the low temperature condition the compressive strength of A, B and C type specimen increased 10.14%, 5.72%, 6.42% the stiffness increased 6.57%, 7.78% and 8.31% respectively. Low temperature condition enhanced matrix stiffness and caused transverse shrinkage of both matrix and fiber. Matrix shrinkage was more obvious than fiber shrinkage, which increased the interfacial force between the fiber and matrix. These two reasons lead the strength and stiffness increasement of OHC specimens under low temperature condition.

The strength of A, B and C type specimens decrease 23.24%,22.78% and 19.80% and the stiffness decrease 9.17%,8.15% and 6.73% under hygrothermal condition. During moisture absorption, immersed water molecules directly influence adhesive strength, decreasing the friction and shear strength of the interface. At high temperature, the strength and stiffness of matrix falls down rapidly. These two reasons make the high degradation of strength and stiffness of the specimens.

4. Conclusion

A series of experiments were conducted to study the effects of environment on static compressive properties of carbon/epoxy composite laminates that are exposed to low temperature, room temperature and hygrothermal environments, respectively. Through systematic investigation, there were four main conclusions to be drawn:

(1) The saturated moisture content of CCF300/BA9916 specimens is around 0.7% under the condition of 70 °C and 80% humidity.

(2) Compressive tests prove that tensile strength, stiffness and hole deformation increase with the content of 0° fiber. The tensile strength and stiffness increase under low temperature environment and hygrothermal condition decreases the tensile strength and stiffness.

References

- [1] Aying Zhang, Dihong Li, Haibao Lu, Dongxing Zhang. Qualitative separation of the effect of voids on the bending fatigue performance of hygrothermal conditioned carbon/epoxy composites. *Mater Design* 2011; 32:4803–4809
- [2] Yi He. Moisture absorption and hygroscopic swelling behavior of an underfill material. *Thermochimica Acta* 2012; 546:143-152
- [3] Pei Sun, Yan Zhao, Yunfeng Lyo, Lili Sun. Effect of temperature and cyclic hygrothermal aging on the interlaminar shear strength of carbon fiber/bismaleimide(BMI) composite. *Mater Design* 2011; 32:4341-4347
- [4] Gautier L, Mortaigne B, Bellenger V. Interface damage study of hydrothermally aged glass-fiber-reinforced polyester composites. *Compos Sci Technol* 1999;59:2329–37.
- [5] Botelho EC, Pardini LC, Crezende M. Evaluation of hygrothermal effects on the shear properties of carall composites. *Mater Sci Eng A* 2007;452–453:292–301.
- [6] Tsenoglou CJ, Pavlidou S, Papaspyrides CD. Evaluation of interfacial relaxation due to water absorption in fiber–polymer composites. *Compos Sci Technol* 2006;66:2855–64.
- [7] Wang Y, Hahn TH. AFM characterization of the interfacial properties of carbon fiber reinforced polymer composites subjected hygrothermal treatments. *Compos Sci Technol* 2007;67:92–101.
- [8] Guo H, Huang YD, Meng LH, Liu L, Fan DP, Liu DX. Interface property of carbon fibers/epoxy resin composite improved by hydrogen peroxide in supercritical water. *Mater Lett* 2009;63:1531-4.
- [9] Khan LA, Nesbitt A, Day R. Hygrothermal degradation of 977–2A carbon/epoxy composite laminates cured in autoclave and Quickstep. *Composites: Part A* 2010;41:942–53.
- [10] Zhou Guangming, Wang Ning. Numerical Analysis and Test Evaluation on Cryogenic Mechanical Properties of Two-Dimensional Woven Composite. *Journal of Nanjing University of Aeronautics and Astronautics* 2014 ; 46:838-844
- [11] Ha SK, Springer GS. Mechanical properties of graphite epoxy composites at elevated temperature. *ICCM-6 & eccm-2*, 1978;4.
- [12] Akay M, Spratt GR, Meenan B. The effects of long-term exposure to high temperatures on the ILSS and iMPact performance of carbon fiber reinforced bismaleimide. *Compos Sci Technol* 2003;63:1053–9.
- [13] Rui-hua Hu, Min-young Sun, Jae-Kyoo Lim. Moisture absorption, tensile strength and microstructure evolution of short jute fiber/polylactide composite in hygrothermal environment. *Mater Design* 2010;31:3167–73.
- [14] Zhan Quan-Wei, Fan Xue-ling, Sun Qin. Effect of hygrothermal environment on static properties of laminated composite with a circular open hole. *Journal of Solid Rocket Technology* 2011;34:764-767
- [15] PENG Lei, ZHANG Jianyu, BAO Rui, F EI Binjun. Effects of hygrothermal and ultraviolet conditions on static properties of T300/ QY8911 laminated composites containing an open hole. *Acta Materiae Composite Sinica*, 26(3), 18-23(2009)
- [16] Timmerman JF, Tillman MS, Hayes BS, Seferis JC. Matrix and fiber influences on the cryogenic microcracking of carbon fiber/epoxy composites. *Composites Part A* 2002;33:323–9.
- [17] Bechel VT, Fredin MB, Donaldson SL, Kim RY. Effect of stacking sequence on microcracking in a cryogenically cycled carbon/bismaleimide composite. *Composites Part A* 2003;34:663–72.
- [18] ASTM D6484/D6484M–04. Standard Test Method for Open-Hole Compressive Strength of Polymer Matrix Composite Laminates[M]. ASTM, 2004