

## IEC-61850 Based Information Modeling of Communication Network for Distributed Energy Resources System

Zi-guan ZHOU<sup>1,a</sup>, Zhi-ping ZHAO<sup>2,b</sup> and Xiao-shan PAN<sup>3,c</sup>

<sup>1</sup> Beijing Smart China Energy Research institute Co., LTD, beijing, China

<sup>2</sup>Xinzhou Power Supply Company of State Grid Shanxi Electric Power Company, shanxi, China

<sup>3</sup> Institute of Microelectronics of Chinese Academy of Sciences, beijing, China

<sup>a</sup> ziguan\_zhou@126.com, <sup>b</sup>13903508058@139.com, <sup>c</sup> shanxiaopan@sina.com

**Keywords:** Distributed Energy Resources; Information Modeling; Communication Network.

**Abstract.** In the field of grid-connected distributed energy resources (DER), telecommunication network plays an important role to carry various information and control messages. With the advantages of high bandwidth and reliability, the communication network has already played an important role to support distributed energy resources. Moreover, IEC61850 protocol has been introduced into the communication field of distributed energy resources. However, the communication system has not been included in the IEC-61850 architecture as IED (Intelligent Electronic Device) information model. Aimed to solve this problem, the information modeling and evaluation method of Communication System for DER is proposed in this paper. The communication architecture of IEC61850 and the IED modeling are introduced. Then, information modeling of communication is conducted, including logic node, port management, and data requirement.

### Introduction

With the rapid development of Distributed Energy Resources (DER), the grid-connection operation of the DER has already presented higher requirements [1]. Currently, existing communication technologies of distributed power-grid can be divided into two categories: wired communications and wireless communications [2]. And the former include Ethernet, Ether Passive Optical Network (EPON), power line communication, etc; while the wireless ones has 3G/4G, WiMax and TD-LTE [3,4]. According to Ref. [5], an evaluation approach has been build and provides important method for determination of appropriate communications in DER grid-connection system. Among these communication technologies, the EPON is strongly recommended to support grid-connection of DER, with higher reliability and better widthband. Moreover, the EPON greatly satisfies those requirements by newly emerging DERs, which has obviously comprehensive advantages [5].

In the aspect of communication protocols, the IEC-61850 has already made information and communication models, according to services characteristics of power-grid system. By abstracting communication interfaces, the object-oriented concept is adopted by IEC-61850 protocol and models of communication services are also built, in order to achieve perfect mapping between power-grid information services and communication technologies [6]. Benefiting from its advanced compatibility and scalability, the IEC-61850 shows great potential and advantages in the field power-grid communication services [7,8]. As the DERs develop with great speed, the IEC61850-7-420 also defined DER oriented information and communication models [9]. And various kinds of Logic Node (LN) are also defined for verified DER devices by IEC-61850, together with all kinds of information services model and communications standards [10]. Thus, the IEC61850-7-420 plays a key role in the field of DER information services and communication. However, those communication network devices have not yet been taken into consideration in the IEC61850-7-420, even through communications networks and devices are necessary fundamental of DERs system. Thus, existing IEC-61850 fails to combine both of DER services and communication system together tightly, which may leads to great inconvenience for related operation about DER.

Therefore, it is of great urgency to take communications systems into IEC-61850 and to build information models for those systems.

Aimed to solve this problem, an information modeling and evaluation method of Communication System for DER is proposed in this paper. The communication architecture of IEC61850 and the IED modeling are introduced. Then, information modeling of EPON is conducted, including logic node, port management, and data requirement.

The rest of this paper is organized as follows. Section 2 discusses the communication services of grid-connected DERs; followed by the EPON for Grid-Connected DER. And the information modeling of EPON system for grid-connected DERs is conducted in Section 3. Section 4 gives the simulation results. Finally, Section 5 concludes this paper.

## Related Works

**Communication Services of DERs System.** As to communication services of grid-connected DERs, the IEC61850-7-420 has already made related standards. By defining logic devices and logic nodes, object-oriented models of all DER devices has been realized by the IEC61850-7-420, except communication system in DER. However, the grid-connection communication is one of key issues in DERs, to provide the fundamental support to grid-connected DERs. Based on the IEC-61850, information services of the DER grid-connection mainly include: monitor, control and alarm.

In fact, monitoring services focus on the detection of the electric power quality and make sure that it satisfies the demand on reliability of the electric power quality, like real-time detection or history records about electric power quality. And the control services mainly conduct real-time operation to turn on/off switches between DERs and power grid, to make sure the security of power-grid. According to the IEC-61850 standard, the reliability of monitoring services must reach 98%, and that of control services must keep up to 99.99%, while the comprehensive error should be under 1.5%. As to real-time performance, monitoring services should keep within 5s~15s, while control services must be less than 5s [11].

**EPON in DERs System.** As a system composed of electricity load devices and micro power resources, distributed energies (DERs) are able to satisfy requirements both of the power quality and safety of power supply, where electric devices are responsible of energy transformation together with communication system. With the aim to make sure the communication quality of grid-connection for distributed power-grid, communication solution with low-cost, high reliability and real-time ability is required. As advantages of EPON system are able to meet these demands mentioned above, the EPON is strongly recommended to be deployed in this field, which is composed by OLT (Optical Line Terminal) and ONU (Optical Network Unit). The EPON based communication system for grid-connection DERs can be shown in Fig.1.

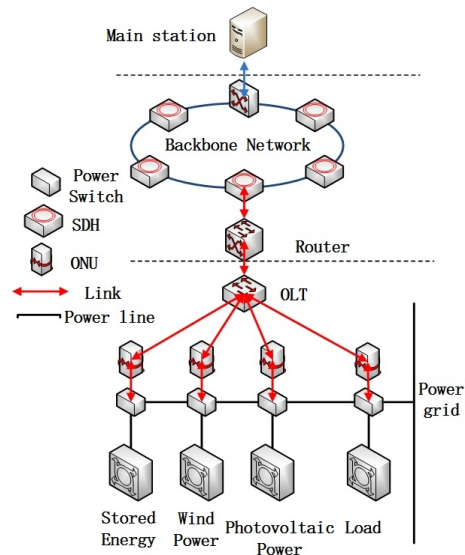

Fig.1. EPON for DER system

In the aspect of communication standards of electric power system, the IEC61850 protocol is mainly used for information modeling of intelligent electronic device (IED) through the object-oriented technologies and the abstract communication services interface. However, the IEC61850 has not yet made information modeling of configuration and management of EPON, which results in great problem of communication network management and maintenance. Aimed to solve this problem, the information model of the EPON system itself is proposed in this work, including logic node, port management, data requirement and alarm control. Furthermore, the information modeling and evaluation method of EPON are both presented.

**Information Modeling of EPON Communication System for DERs**

The information modeling of EPON system for grid-connected DERs is conducted according to the standard of the IEC61850-7-420, where the OLT and ONUs are all transformed into IEDs. And visible and accessible logic nodes (LN) are generated from these IEDs to complete the information modeling of EPON system. The IEC61850 adopts the object oriented concept to define both of the information model and the communication model. According to this concept, the IEC61850-7-420 not only designs a number of hierarchical classes but also build a hierarchical information object model for system. Considering the special architecture of EOPN, information models of the OLT and each ONU are both conducted in this section.

**Principle of Information Modeling.**The IEC61850-7-420 makes full use of the object-oriented concept to make this communication standard. By designing hierarchical classes, standard information model could be built in the manner of abstracted data [13-14]. According to the IEC61850-7-420 standard, information modeling of EPON system must take the OLT device and ONU devices as IED devices. Thus, information modeling for EPON must follow the principle as follow.

- (1) New logic node class and function node class must be defined for OLT device and ONU devices in EPON system, since existing IEC-61850 has not yet made any logic node class or function node class for communication devices. And these classes must be defined with "Z" as the head of name.
- (2) Each device should be considered as an independent IED object to conduct information modeling. And each Logic Device of IED object contains at least three Logic Nodes according to its function.
- (3) Logic Node is the minimum unit in IED device, and a whole Logic Device is composed by several Logic Nodes.

(4) Data Object and Data Attribute are main content of Logic Node and Logic Device.

**Information Modeling of OLT device.** By the object oriented concept, it can be achieved to build models of the device configuration management class ZSPM and the device inquiry management class ZSTS, and their abstraction is given in Table.1 and Table.2.

Table 1. Modeling of ZSTS class of OLT

Name	Feature	Discription	M/O
DevType	SPS	Device Type	M
OnuNum	INS	ONU Number	M
SysBandWidth	INS	System Capacity	M
PortPower	INS	Port Optical Power	M

Table 2. Modeling of ZSPM class of OLT

Name	Feature	Discription	M/O
PortId	INC	Port ID	M
PortBandWidth	INC	Port Bandwith	M
PortMode	INC	Communication Mode	M
PortEnable	SPC	Port Enablility	M

**Information Modeling of ONU devices.**The same with the information modeling of OLT device, the information modeling of each ONU can also be performed by similar way, including the device configuration management class ZSPM and the device acquisition management class ZSTS. Tab. 3 and Tab.4 define the abstraction information model.

Table 3. Modeling of ZSPM class of ONU

Name	Feature	Discription	M/O
OnuIP	INC	IP Address	M
OnuBndWd	INC	ONU Bandwidth	M
PortDup	INC	Communication Mode	M
PortEn	SPC	Port Enablility	M

Table 4. Modeling of ZSTS class of ONU

Name	Feature	Description	M/O
OnuID	INS	ONU Number	M
LinkState	INS	Link State	M
BndWd	INS	Port Bandwith	M
PortMode	INS	Communication Mode	M
PortEnable	SPS	Port Enablility	M
PortTraff	INS	Port Traffic Load	M
PortPower	INS	Port Optical Power	M

**Implement of information modeling.** According to the demands of communication devices in DERs, the modeling implement of EPON devices is done through software approach, on the base of IEC-61850-7-420 standard. Each functional model is depicted in Fig.2, which includes the device abstraction model, the information modeling model and the modeling mapping model.

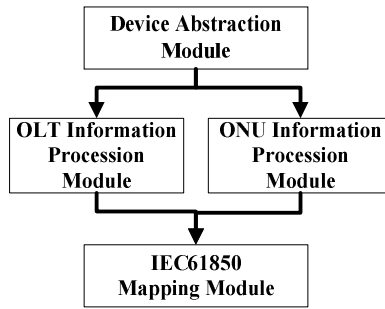

Fig.2. Modeling Implement of EPON

(1) Device Abstraction Model: the OLT device abstracts information from IEC-61850 message and judges which device the information belonging to. If it is related to OLT, this information will be send to the OLT information proccession model; otherwise, it will be given to the ONU information proccession model.

(2) OLT Information Proccession module: this module is responsible of the processing of the OLT modeling information.

(3) ONU Information Proccession module: this module is responsible of the processing of the ONU modeling information.

(4) Modeling mapping module: transforms IEC-61850 information model into MMS message.

**Testing Results**

To evaluate the IEC-61850 based information modeling of EPON devices for DER grid-connection, related OLT device and ONUs devices is developed following the IEC-61850-7-420 standard and the grid-connected DER simulation platform is also build, which contains photovoltaic power station with 50 kWp capacity and wind power station with capacity of 20 kWp. Moreover, each DER is equipped with those EPON devices proposed in this article, and the service inter-cooperation between each DER and the main station is realized through this EPON system, as is shown in Fig.3.

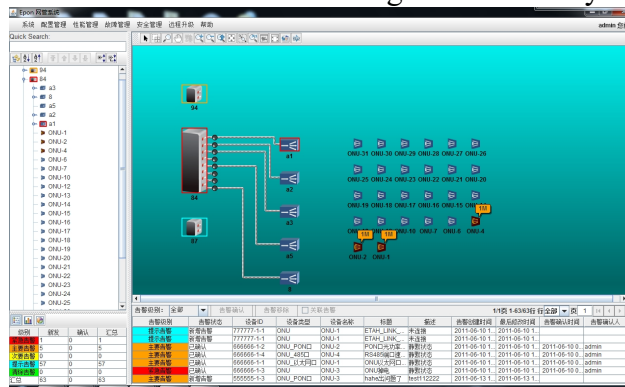

Fig.3. Interface of EPON system information modeling

**Conclusion**

Current IEC61850-7-420 had not yet defined information model for communication device, which had brought great problem to monitor grid-connected DER. With the aim to solve this problem, information modeling of EPON was conducted, including logic node, port management, data requirement, in which communication architecture of IEC61850 and the IED modeling were introduced. Experimental results showed the validation of the proposed information modeling.

## References

- [1] Li, Guoqing. "Research on Communication Modes for Distributed Generation Access to Distribution Network." *Modern Electric Power*, 2011, 28(2): 79-83.(in Chinese)
- [2] Huang, Sheng. "Analysis on the demand for communication services in smart distribution network and communication technical scheme." *Telecommunications for Electric Power System*. 2010, 31(212): 10-17. (in Chinese)
- [3] Hu, Jianwu. "Analyses and Comparisons of WiMAX & McWiLL." *Telecom Engineering Technics & Standardization*, 2007, 20(8): 26-29. (in Chinese)
- [4] Runze WU, Wang X, Zhang X, et al. An Evaluation Method for Monitoring Communication of Grid-connected Distributed Energy Resources [J]. *Automation of Electric Power Systems*, 2014, 38(8):72-77. (in Chinese).
- [5] TAN Wen-shu. An introduction to substation communication network and system-IEC61850 [J]. *Power System Technology*, 2001, 25(9): 8-11. (in Chinese)
- [6] IEC61850-7-1 communication networks and systems in substations , part 7-1 basic communication structure for substation and feeder equipment-principles and models[S]
- [7] Prat R, Rodriguez G, Magnago F. Monitoring and Controlling Services for Electrical Distribution Systems Baed on the IEC 61850 Standard[J]. *Energy & Power Engineering*, 2011, 03. (in Chinese)
- [8] Ustun T S, Ozansoy C, Zayegh A. Modeling of a Centralized Microgrid Protection System and Distributed Energy Resources According to IEC 61850-7-420[J]. *IEEE Transactions on Power Systems*, 2012, 27(3):1560-1567. (in Chinese)
- [9] Cleveland F M. Iec 61850-7-420 Communications Standard For Distributed Energy Resources (DER) [C]// *Power and Energy Society General Meeting - Conversion and Delivery of Electrical Energy in the 21st*2008:1-4.
- [10] IEEE. IEEE Standard for Interconnecting Distributed Resources with Electric Power Systems[J]. *Institute of Electrical & Electronics Engineers Inc*, 2003:1-28. (in Chinese)
- [11] Zhang X J, Jun-Min W U. Research on High Availability Technologies for Large-Capacity EPON in Smart Distribution Grids [J]. *Electric Power Information Technology*, 2013, 11(6):1-6. (in Chinese)
- [12] Honeth N, Wu Y, Etherden N, et al. Application of the IEC 61850-7-420 data model on a Hybrid Renewable Energy System[C]// *PowerTech, 2011 IEEE TrondheimIEEE*, 2011:1-6. (in Chinese)
- [13] Ustun T S, Ozansoy C, Zayegh A. Distributed Energy Resources (DER) object modeling with IEC 61850-7-420[C]// *Universities Power Engineering Conference (AUPEC)*, 2011 21st AustralasianIEEE, 2011:1 - 6.
- [14] Liu Y, Huang W, Yu T. Information modeling and implementation of monitoring and control system in large scale battery energy storage system[C]// *Advances in Power System Control, Operation and Management (APSCOM 2012)*, 9th IET International Conference on IET, 2012:1-5