

# The Design for Family Harmful Gas Detection Device

Lihua LIU<sup>1, a</sup>

<sup>1</sup>School of Electrical and Information Engineering, Liaoning Institute of Science and Technology, Benxi, 117004, China

<sup>a</sup>benxiliulihua@sina.com

**Keywords:** harmful gas, MCU, sensor, dial number

**Abstract.** The paper introduces the design for domestic harmful gas detection device. By choose the corresponding sensor, and obtains the harmful gas information; the operation amplifier amplifies the signal. The MCU employees the ADC to get the digital information and read the alarm value set by the user, and decides whether into the alarm status or not. The alarm method includes the sound alarm, light alarm and telephone alarm. By the experiment, prove the design is stable and reliable.

## 1 Design Objective

Harmful gas includes coal gas, natural gas and smoke when fire occurs in our diary living. The coal gas and natural gas can provide the necessary heat for cooking. But they are deadly for human being. So it is necessary to detect them and give out alarm if possible. When the fire happens, if no one is at home, it is urgent to tell the house owner the disaster.

In this paper, it will realize the device for the gas detection, fire detection and gives out the alarm.

## 2 Design Realization

**Sensor.** The gas sensor is a key component for the device. We choose MQ-2 as smoke sensor. It is illustrated in Fig.1



Fig.1 MQ-2 sensor

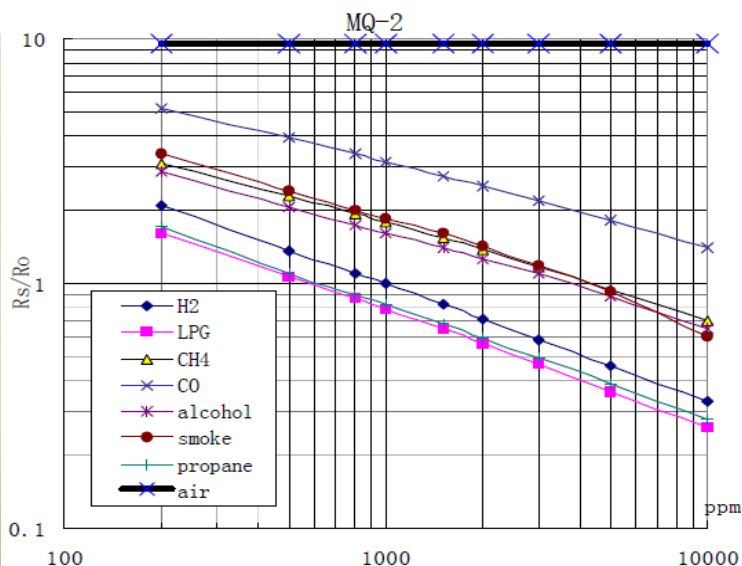

Fig.2 characteristic curve of MQ-2

In Fig.1, it is the appearance of MQ-2 sensor. From the Fig.2, it is its characteristic curve of the sensor from its user manual. The Figure tells us the sensor can detect the usual gas in our family. When the gas content varies, the resistance of the sensor will vary, too. According to the character, we can detect the gas content in the air [1,2].

In Fig.3, it is the sensor circuit. The pins VCC, GND is the heating pins and voltage is needed on them for heating. This is different from the other sensor and it needs the suitable work temperature. Only in the suitable temperature, the sensor can act as in the Fig.2. The variable resistance embodies

on the pin A,B and the R71 series with sensor resistance. According to the Fig.2 and the experiment, the output voltage named  $V_o$  in Fig.3 increases with the gas content increasing.

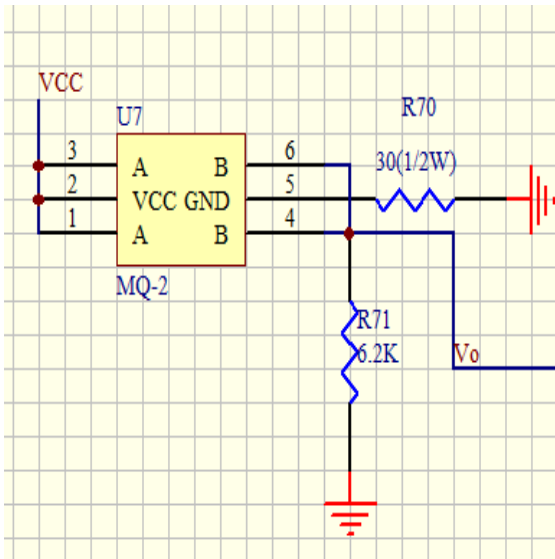

Fig.3 sensor circuit

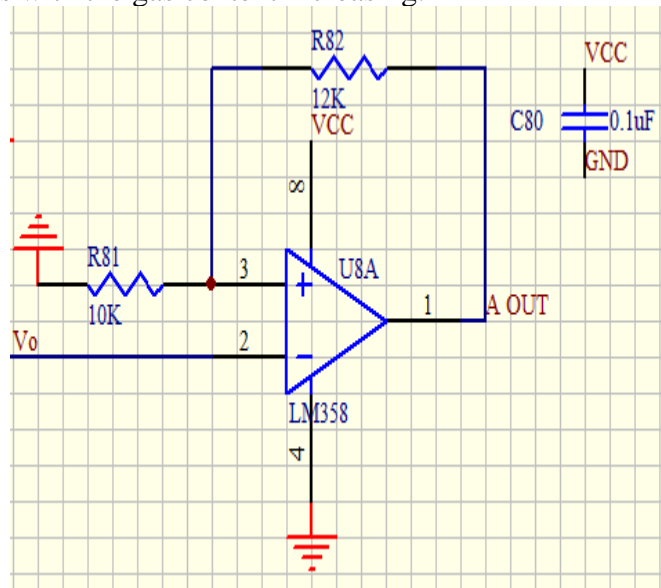

Fig.4 amplification circuit

**Amplification Circuit.** The output voltage in the safety surrounding is about 1 volt, and the value in dangerous surrounding often can not change obviously, so it needs the amplification circuit. In the Fig.3, the circuit is noninverting circuit. The capacity C80 is the filter capacity, which reduces the noise of power supply.

The amplification factor can be decided by formula 1:

$$A_u = 1 + \frac{R82}{R81} \quad (1)$$

In above formula, the amplification factor is 1.3.

**The Analogy Digital Converter (ADC) Circuit.** The ADC circuit accepts the signal from the operation amplifier LM358, and then converts it to the digital signal, which can be understood by the MCU.

The circuit is illustrated by Fig.5

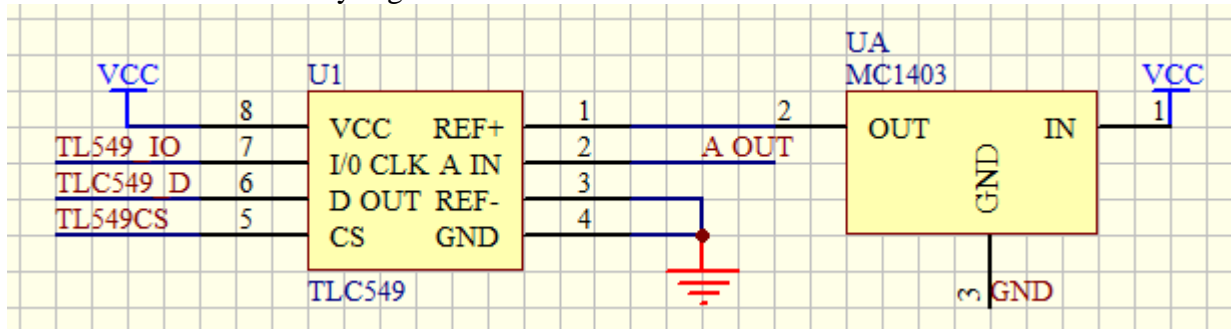

Fig.5 ADC circuit

In the Fig.5, the ADC IC is TLC549 [3]. It has analogy input pins, pin number is 2; the reference input pin and the digital pins, which can transmit the digital signal to the MCU. TLC549 is an 8 bit ADC. The analogy input and digital output can be described as formula 2:

$$\frac{A_{in}}{V_{ref}} = \frac{D}{256} \quad (2)$$

In the above formula, the  $A_{in}$  is the analogy input voltage value;  $V_{ref}$  is the voltage reference value, it requires the accurate and stable input voltage.  $D$  is the digital value. From the formula 2, we know the output digital value is proportional to the analogy signal.

In the Fig.5, choose MC1403 as voltage reference. Its input value is about 5 volt and the output is accurate and low noise 2.5 volt voltage as reference.

MCU. MCU is the brain of the total system. In the design, we employees STC89C52 as the MCU, it is illustrated in the Fig.6.[4]

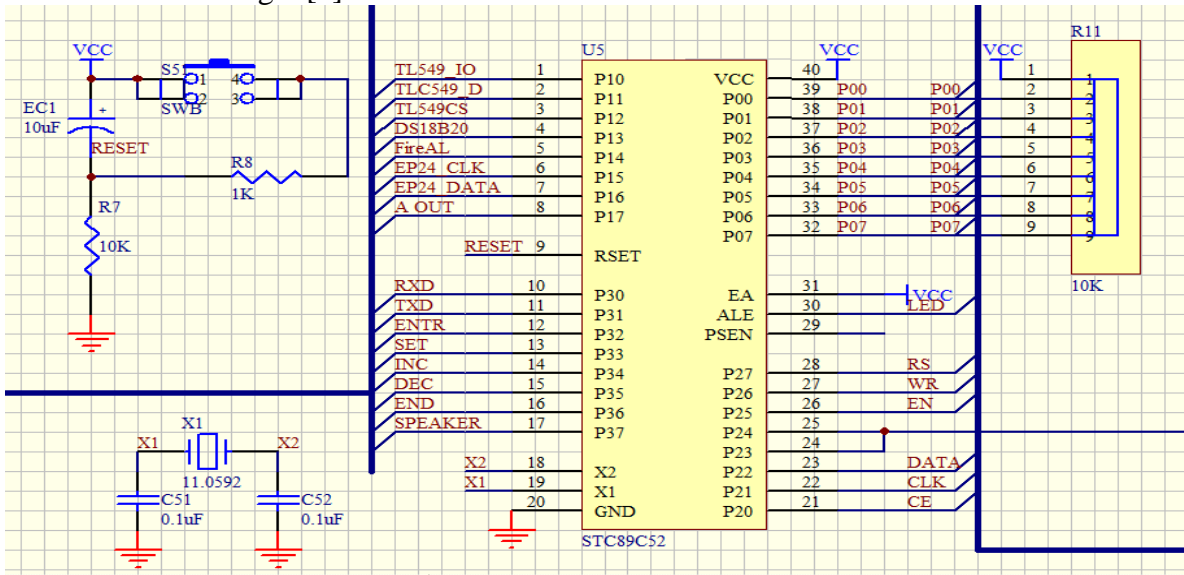

Fig.6 the MCU circuit

In the Fig.6, MCU circuit consists of four parts. The main body is the STC89C52. Component X1,C51,C52 is the crystal oscillation circuit, it provide the system clock pulse. The R7 ,R8 and S5 is resetting circuit. They provide the reset pulse and manual reset function. The fourth part is R11; it provides the pull up resistance because of the no pull up resistance in the port 0.

The pins P10, P11,P12 connects with the TLC549 and obtain the ADC result from TLC549.

**Human and Machine Interface.** The interface can receive the information from the user and displays the relative information on the display component.

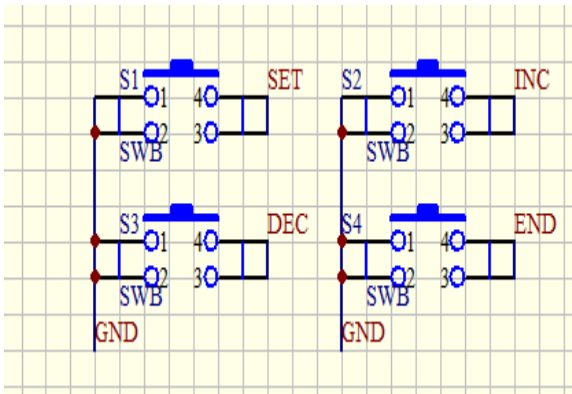

Fig.7 keyboard circuit

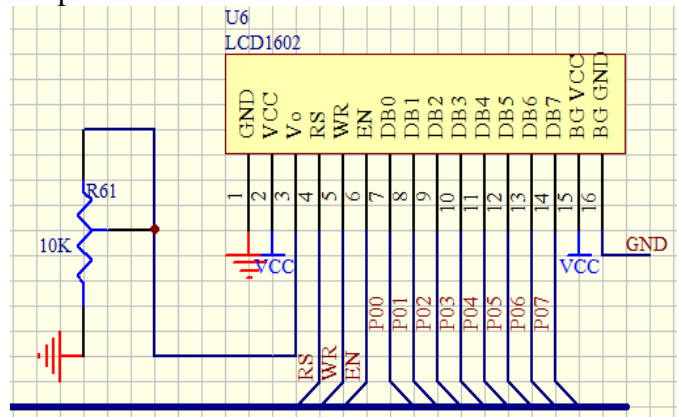

Fig.8 display component

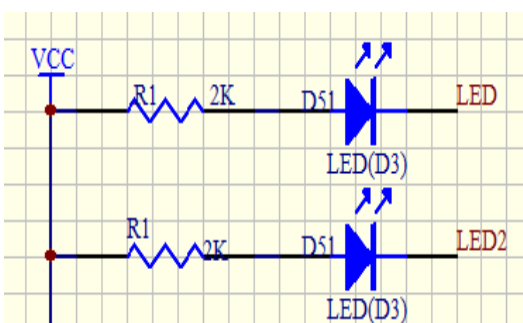

Fig.9 light alarm circuit

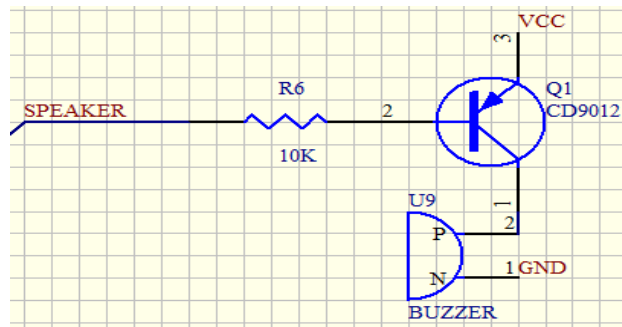

Fig.10 sound alarm circuit

In Fig.7, we design the standard 4 key keyboard. The user can input the information to the MCU, such as the telephone number and alarm value.

In Fig.8, we choose the LCD1602 as the display component. The data bus connects with the P0 port and the control signal is connects with the pins P2.7, P2.6 and P2.5.

**Alarm Circuit.** The alarm circuit function includes the sound alarm, light alarm and telephone alarm. The sound alarm and light alarm can give out the alarm to local human being; and the telephone alarm can dial the mobile number to the corresponding mobile to human being outside. The Fig.9 and Fig.10 is the circuit. In the Fig.10, the sound component is the active buzzer. The transistor Q1 can provide the control function.

In Fig.11, it is the telephone alarm circuit. When alarm happens, the MCU give out the alarm not only by the sound and light, but also controls the dial chip HT9200 to generate the dial signal enlarged by the transistor Q2,Q3 and rectified by the four diode ,then put the end signal to the telephone line. The signal derives from the mobile number input by the user, stored by MCU [5,6].

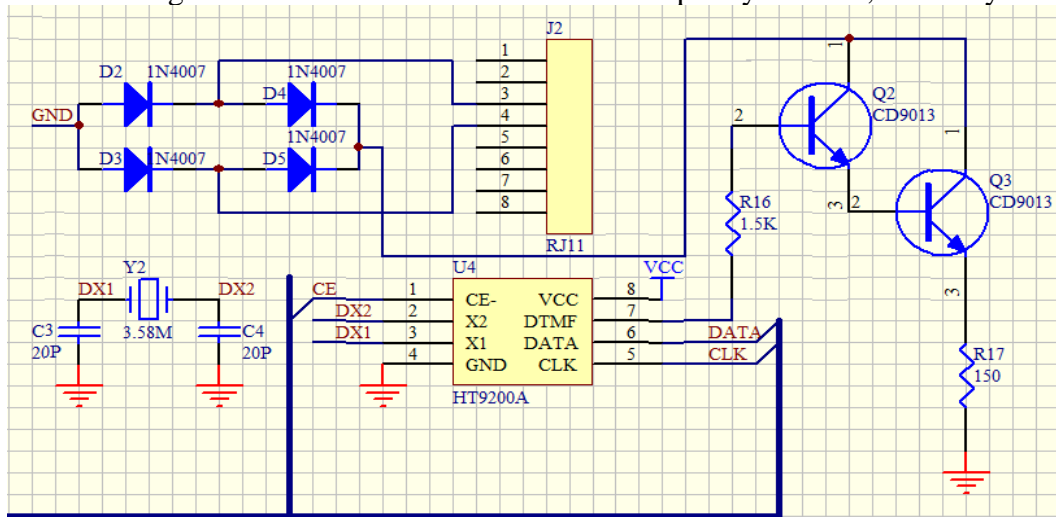

Fig.11 telephone alarm circuit

### 3 Conclusion

By using the sensor MQ-2 as the harmful gas sensor, operation amplifier amplifies the output signal. ADC TLC549 converts the analogy signal to digital signal. MCU obtains the digital signal, and then according to the alarm value, decides the alarm status.

We have finished the hardware realization; the hardware can be operated by the software in the MCU. By the experiment, the system can receive the user parameter and stores it into its Rom. The MCU displays the corresponding information on the LCD1602. When the harmful gas reaches its limitation, the MCU can give out the sound and light alarm. It can dial through telephone line and user's mobile can receives the call.

### References

- [1] Wenjie Liu, Maoqin Zhang and Xiaoyu Zhou: *CECNet, 2011 International Conference on*, (Xianning, China, April 16-18, 2011), p.1819.
- [2] Information on <http://www.hwsensor.com>.
- [3] Information on <http://www.TI.com>.
- [4] Information on <http://www.stm32.com>.
- [5] Information on <http://www.holtek.com>.
- [6] Tingyun Chen, Yimin Yang, Song Zhang and Zhichang Luo, *Intelligent Information Technology Application, Workshop on*, (Zhang jiajie,China,December 2-3,2007), p107-111.